

Copyright. All information furnished within this document, electronic file or design correspondence is the property of Den Hartog industries, Inc. and shall not be used, disclosed to others or copied without the expressed written consent of Den Hartog Industries, Inc.

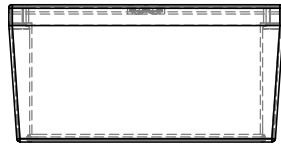

A

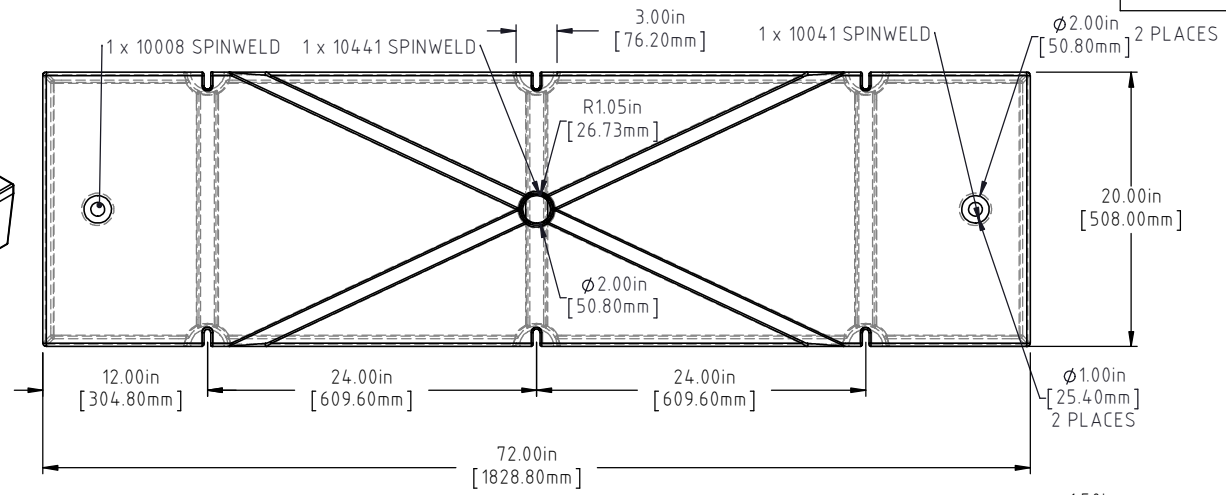
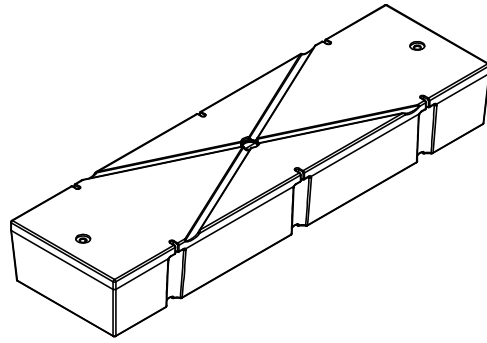
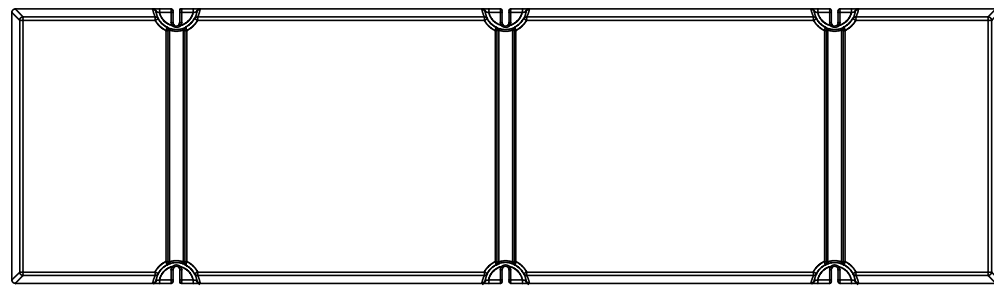
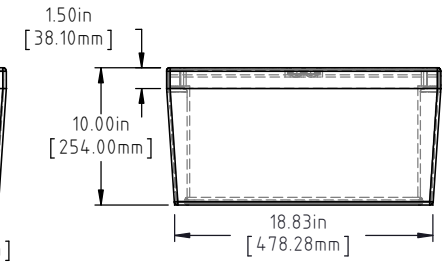
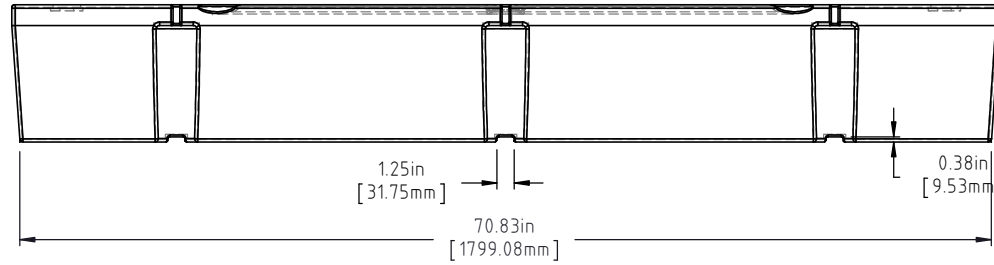

A

NOTE: BUOYANCY 450.00 LBS. (204.12 KG.)

				DRAWN / DATE ADH 4/9/12	MATERIAL 10548 RESIN
A	BOTTOM AND SIDE VIEWS ADDED TO PRINT	ADH 12/4/14	2971	APPRO. / DATE REH 4/9/12	
REV	DESCRIPTION	BY / DATE	CCN		
ALL DIMENSIONS ARE IN DECIMAL INCHES TOLERANCES UNLESS OTHERWISE SPECIFIED		THIRD ANGLE PROJECTION ANSI 14.5M		SHOT WEIGHT: 30 LBS.(13.61 KG.)	NOTES: 1. NOM. WALL = .180
POLYETHYLENE		METAL DECIMAL ± .125" FRACTION ± 1/4" ANGLE ± 1°		SHIPPING WEIGHT: FF 38 LBS. (17.24 KG.)	
±1% @ 68°F				FINISH:	



Den Hartog
INDUSTRIES, INC.

Ace Roto-Mold Injection Molding Blow Molding Sowjoy

4010 HOSPERS DRIVE S. BOX 425, HOSPERS, IOWA 51238-0425

DESCRIPTION 2072-10 FLOAT	
SCALE N.S.	PART NO. 2072-10