

Copyright. All information furnished within this document, electronic file or design correspondence is the property of Den Hartog industries, Inc. and shall not be used, disclosed to others or copied without the expressed written consent of Den Hartog Industries, Inc.

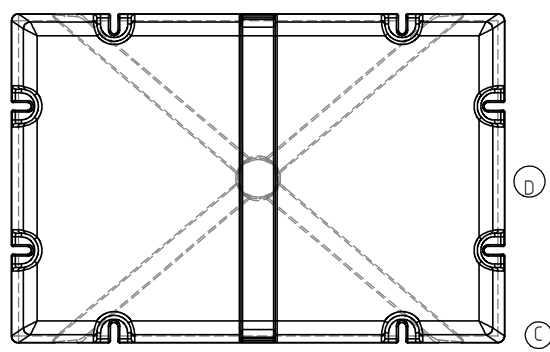
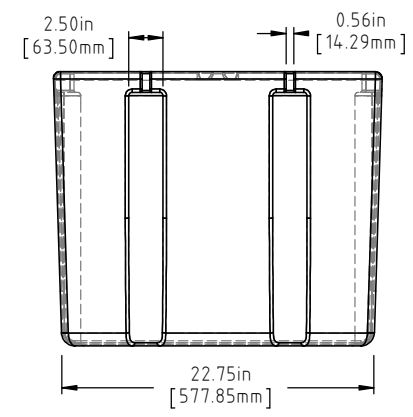
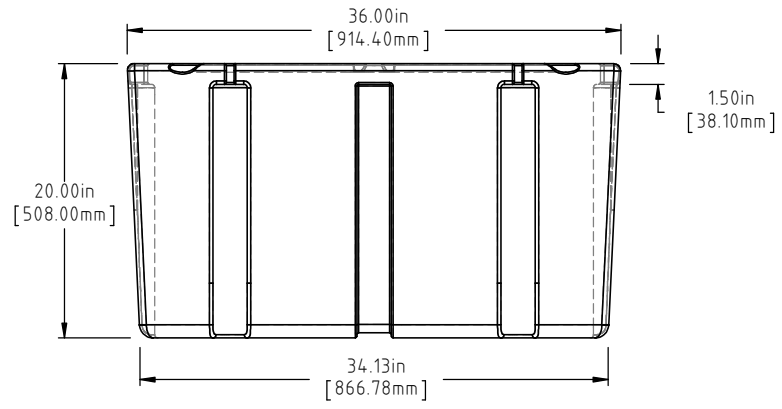
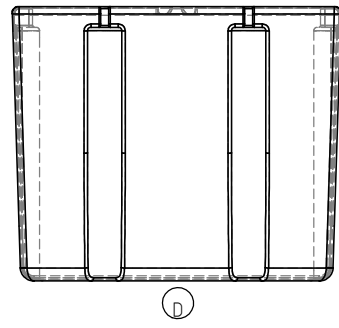
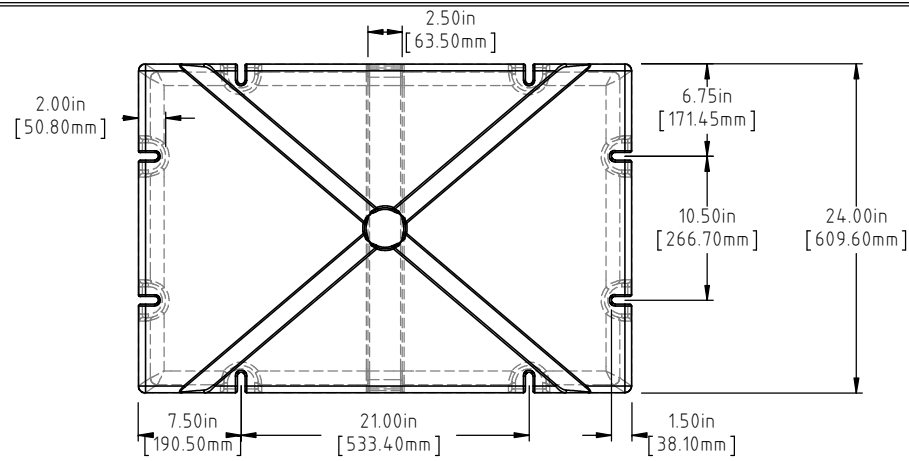

D	BOTTOM AND SIDE VIEWS ADDED TO PRINT	ADH 12/4/14	2971
C	33 LBS WAS 31 LBS, 540 LBS WAS 538 LBS	ADH 6/19/12	2420
B	METRIC DIMENSIONS ADDED	ADH 6/12/08	1685
A	ADDED BUOYANCY	GWC 1/3/07	
A	CHANGE WEIGHT FF WAS 32	GWC 1/3/07	
1	CHANGE WEIGHT	11/16/94	
REV	DESCRIPTION	BY / DATE	CCN

DRAWN / DATE	MATERIAL
DEH 10/15/93	POLYETHYLENE
APPRD. / DATE	
ADH 11/5/07	

(C) (A) NOTE: BUOYANCY IS 540 LBS.(244.94 KG.)

ALL DIMENSIONS ARE IN DECIMAL INCHES
TOLERANCES UNLESS OTHERWISE SPECIFIED
POLYETHYLENE
±1% @ 68°F

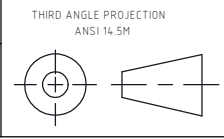

SHOT WEIGHT: 22 LBS.(9.98 KG.)
SHIPPING WEIGHT: SEE NOTES
FINISH:

NOTES: (A) (C)
1.) AF 22 LBS.(9.98 KG.)
2.) FF 33 LBS.(14.97 KG.)
3.) 0.150in (3.81mm) NOM. WALL



Den Hartog
INDUSTRIES, INC.

Ace Roto-Mold Injection Molding Blow Molding Sowjoy
4010 HOSPERS DRIVE S. BOX 425, HOSPERS, IOWA 51238-0425

DESCRIPTION	24 X 36 X 20 FLOAT
SCALE	N.S.
PART NO.	2436-20