

Copyright. All information furnished within this document, electronic file or design correspondence is the property of Den Hartog Industries, Inc. and shall not be used, disclosed to others or copied without the expressed written consent of Den Hartog Industries, Inc.

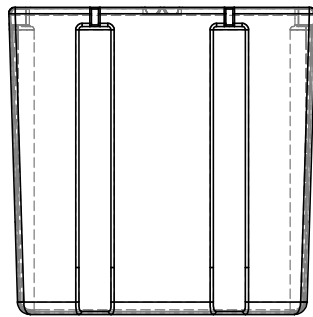

D

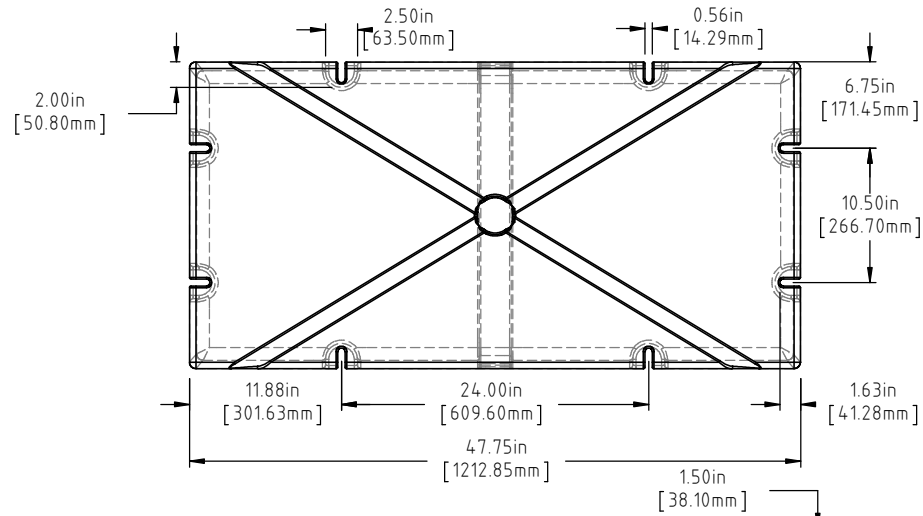
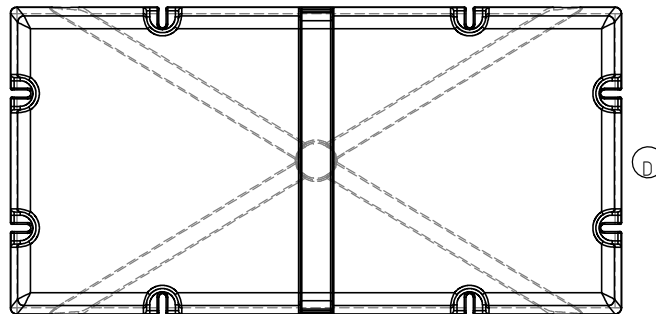
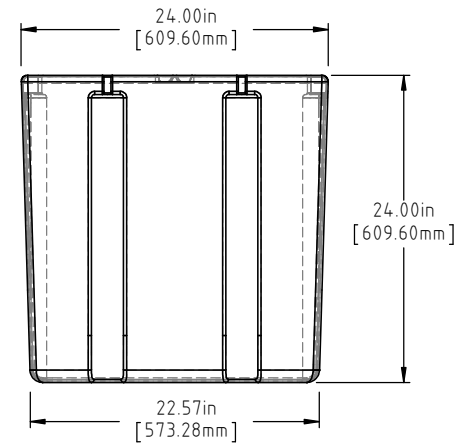
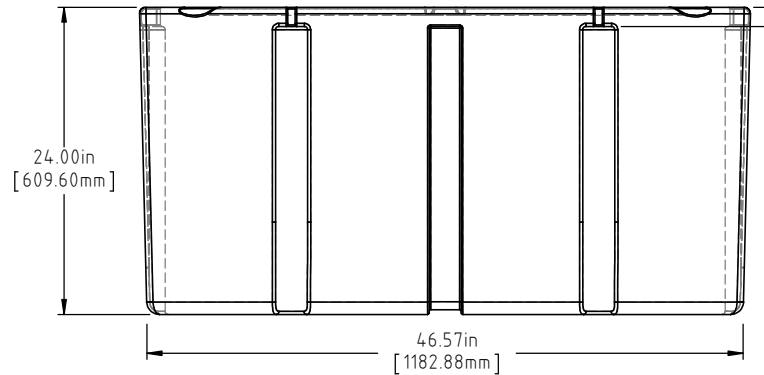

D

(A)(C) NOTE: BUOYANCY IS 866 LBS.(392.81 KG)

D	BOTTOM AND SIDE VIEWS ADDED TO PRINT	ADH 12/4/14	2971
C	50 LBS WAS 49 LBS, 866 LBS WAS 850 LBS	ADH 6/20/12	2420
B	METRIC DIMENSIONS ADDED	ADH 6/12/08	1685
A	ADD BUOYANCY NOTE	GWC 1/8/07	
A	CHANGE WEIGHTS FF WAS 50	GWC 1/8/07	
1	CHANGE WEIGHTS	11/16/94	
REV	DESCRIPTION	BY / DATE	CCN

DRAWN / DATE REH 11/23/99	MATERIAL POLYETHYLENE
APPRD. / DATE ADH 11/5/07	

ALL DIMENSIONS ARE IN DECIMAL INCHES
TOLERANCES UNLESS OTHERWISE SPECIFIED
POLYETHYLENE
±1% @ 68°F

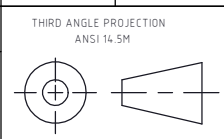

SHOT WEIGHT:
35 LBS.(15.88 KG.)
SHIPPING WEIGHT:
SEE NOTES
FINISH:

NOTES: (A)(C)
1.) AF 35 LBS.(15.88 KG.)
2.) FF 50 LBS.(22.68 KG.)
3.) 0.150 IN (3.81 mm) NOM. WALL



Den Hartog
INDUSTRIES, INC.

Ace Roto-Mold Injection Molding Blow Molding Sowjoy
4010 HOSPERS DRIVE S. BOX 425, HOSPERS, IOWA 51238-0425

DESCRIPTION 24 X 48 X 24 FLOAT	SCALE N.S.	PART NO. 2448-24
-----------------------------------	---------------	---------------------