

© DEN HARTOG INDUSTRIES, INC.

Copyright. All information furnished within this document, electronic file or design correspondence is the property of Den Hartog Industries, Inc. and shall not be used, disclosed to others or copied without the expressed written consent of Den Hartog Industries, Inc.

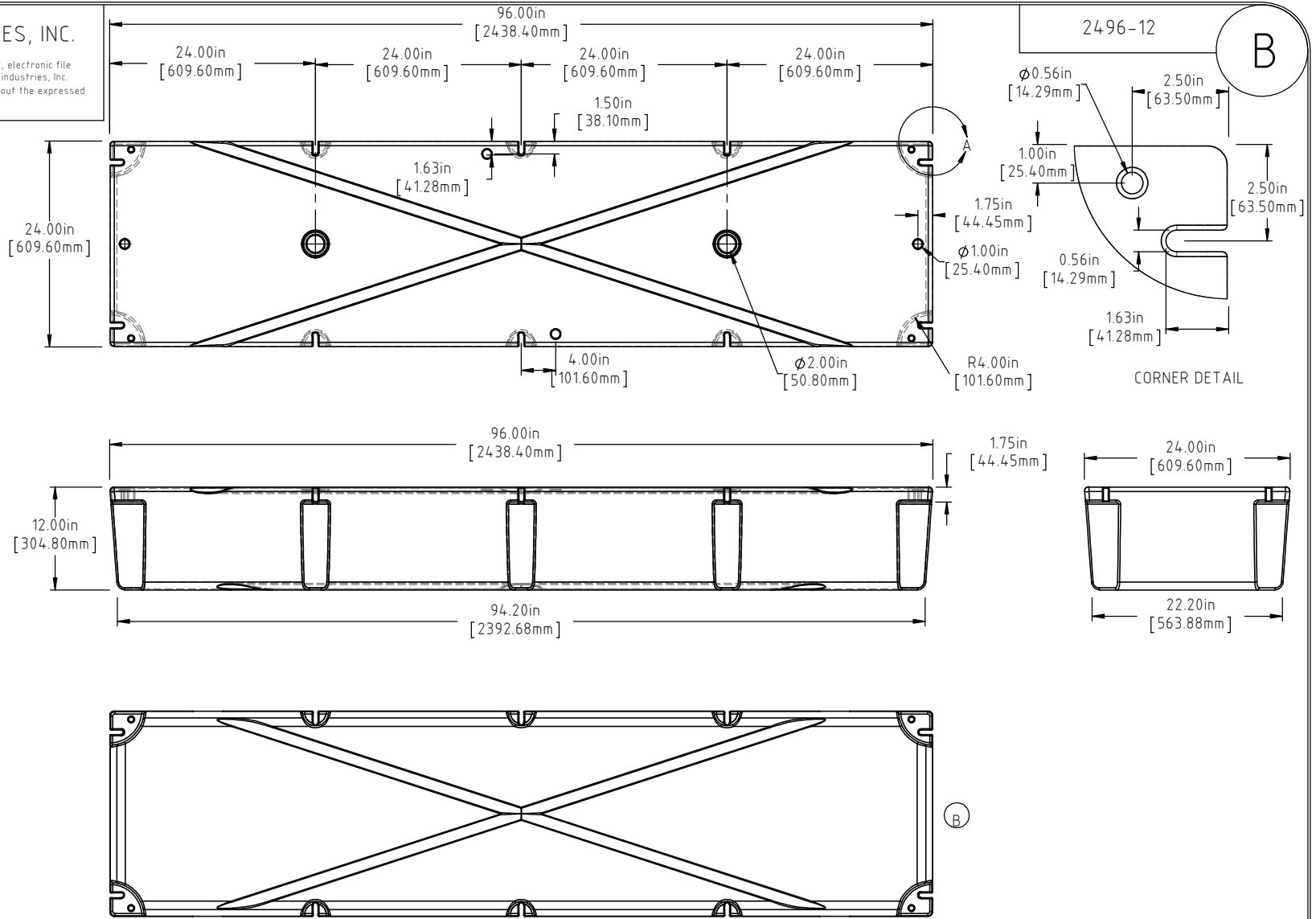

(A) NOTE: BUOYANCY 866.00 LBS.(392.81 KG.)

B	BOTTOM AND SIDE VIEWS ADDED TO PRINT	ADH 12/4/14	2971	DRAWN / DATE DHJ 9/19/07	MATERIAL POLYETHYLENE
A	866 LBS WAS 547 LBS	ADH 6/20/12	2420	APPRO. / DATE REH 12/5/07	
REV	DESCRIPTION	BY / DATE	CCN		
ALL DIMENSIONS ARE IN DECIMAL INCHES TOLERANCES UNLESS OTHERWISE SPECIFIED		THIRD ANGLE PROJECTION ANSI 14.5M		SHOT WEIGHT: 48 LB.(19.05 KG.)	NOTES: 1.) AF = 48 LB.(19.05 KG.) 2.) FF = 64 LB.(29.03 KG.) 3.) 0.150in (3.81mm) NOM. WALL
POLYETHYLENE	METAL DECIMAL ± .125" FRACTION ± 1/4" ANGLE ± 1°	SHIPPING WEIGHT: SEE NOTES		FINISH:	
±1% @ 68°F					

Den Hartog

INDUSTRIES, INC.

Ace Roto-Mold Injection Molding Blow Molding Sowjoy

4010 HOSPERS DRIVE S. BOX 425, HOSPERS, IOWA 51238-0425

DESCRIPTION	24 x 96 x 12 FLOAT	
SCALE	N.S.	PART NO. 2496-12