

© DEN HARTOG INDUSTRIES, INC.

Copyright. All information furnished within this document, electronic file or design correspondence is the property of Den Hartog Industries, Inc. and shall not be used, disclosed to others or copied without the expressed written consent of Den Hartog Industries, Inc.

3648-20

D

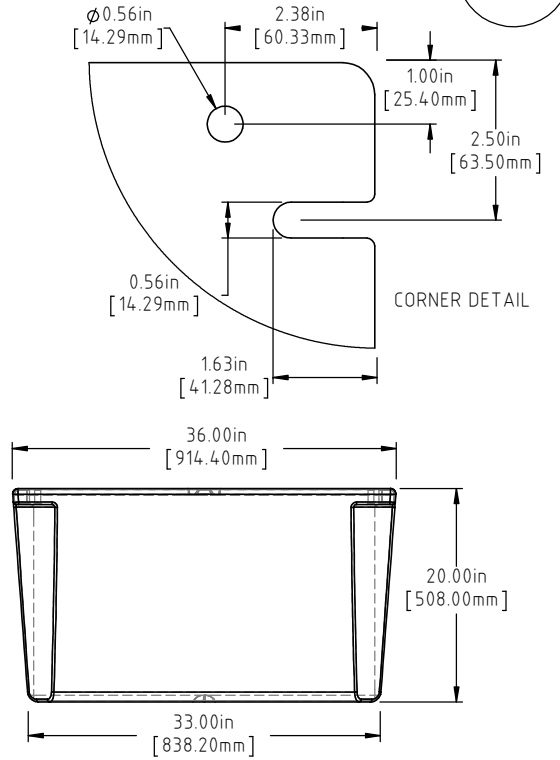
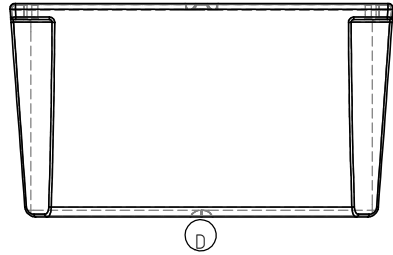
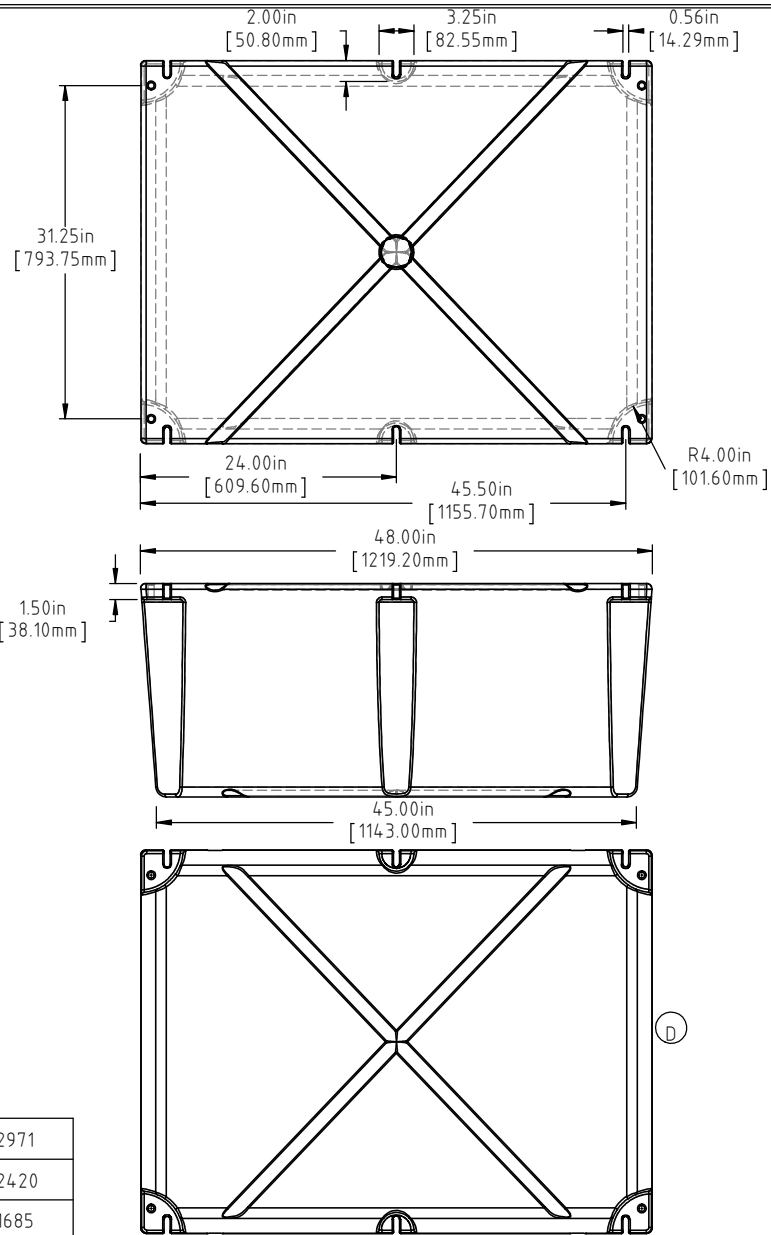

D	BOTTOM AND SIDE VIEWS ADDED TO PRINT	ADH 12/4/14	2971
C	62 LBS WAS 59 LBS, 1088 LBS WAS 1066 LBS	ADH 6/21/12	2420
B	METRIC DIMENSIONS ADDED	ADH 6/6/08	1685
A	ADD BUOYANCY NOTE	GWC 1/8/07	
A	CHANGE WEIGHTS AF WAS 37 FF WAS 66	GWC 1/8/07	
1	CHANGE WEIGHTS	11/18/94	
REV	DESCRIPTION	BY / DATE	CCN

DRAWN / DATE DHJ 4/4/94	MATERIAL POLYETHYLENE
APPRD. / DATE ADH 11/5/07	

NOTE: BUOYANCY IS 1088 LBS.(493.51 KG)



**Den Hartog**  
INDUSTRIES, INC.

Ace Roto-Mold Injection Molding Blow Molding Sowjoy

4010 HOSPERS DRIVE S. BOX 425, HOSPERS, IOWA 51238-0425

ALL DIMENSIONS ARE IN DECIMAL INCHES  
TOLERANCES UNLESS OTHERWISE SPECIFIED  
POLYETHYLENE METAL  
DECIMAL ± .125"  
FRACTION ± 1/4"  
ANGLE ± 1°  
±1% @ 68°F

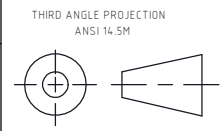

SHOT WEIGHT:  
40 LBS.(18.14 KG.)  
SHIPPING WEIGHT:  
SEE NOTES  
FINISH:

NOTES: (A) (C)  
1.) AF 40 LBS.(18.14 KG.)  
2.) FF 62 LBS.(28.12 KG.)  
3.) 0.150 IN (3.81 mm) NOM.  
WALL

DESCRIPTION 36 X 48 X 20 FLOAT	SCALE N.S.	PART NO. 3648-20
-----------------------------------	---------------	---------------------