

© DEN HARTOG INDUSTRIES, INC.

Copyright. All information furnished within this document, electronic file or design correspondence is the property of Den Hartog Industries, Inc. and shall not be used, disclosed to others or copied without the expressed written consent of Den Hartog Industries, Inc.

48120-20

B

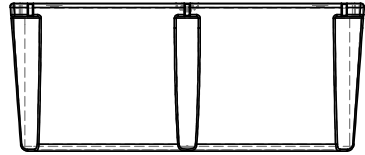
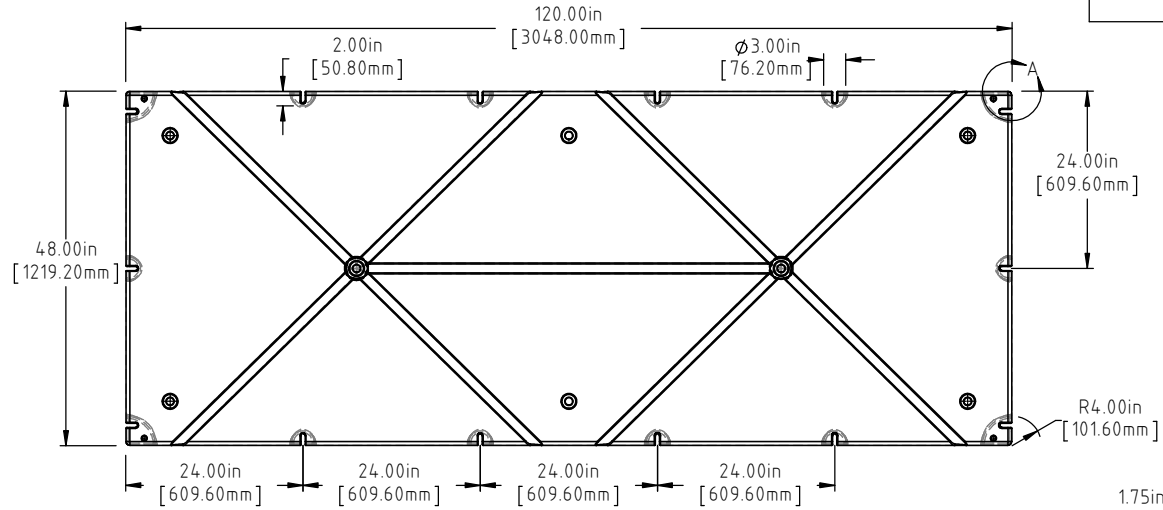
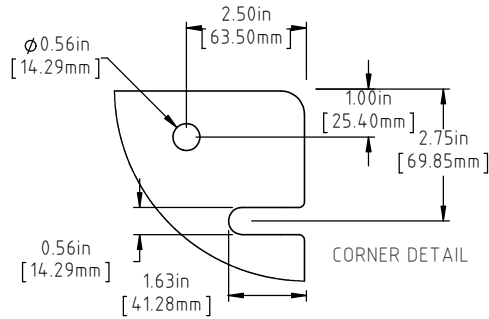

B

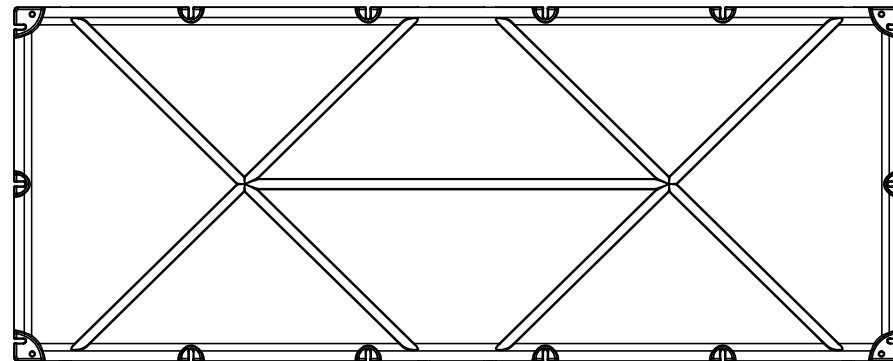
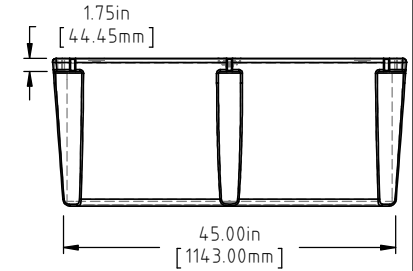
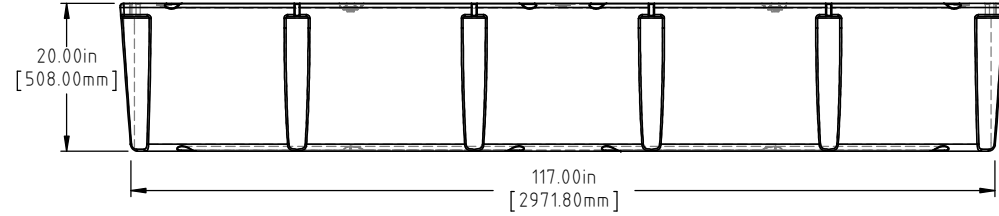

B

NOTE: BUOYANCY 3692.00 LBS.(1674.66 KG.)

B	BOTTOM/SIDE VIEWS ADDED TO PRINT.	ADH 12/4/14	2971	DRAWN / DATE DHJ 6/27/11	MATERIAL POLYETHYLENE
A	177 LBS WAS 176 LBS, 3692 LBS WAS 3690 LBS	ADH 6/28/12	2420	APPRD. / DATE REH 10/24/11	
REV	DESCRIPTION	BY / DATE	CCN		
ALL DIMENSIONS ARE IN DECIMAL INCHES TOLERANCES UNLESS OTHERWISE SPECIFIED		THIRD ANGLE PROJECTION ANSI 14.5M		SHOT WEIGHT: 111 LBS.(50.35 KG.)	NOTES: (A) 1.) AF 111 LBS.(50.35 KG.) 2.) FF 177 LBS.(80.29 KG.) 3.) 0.150in(3.81mm) NOM. WALL
POLYETHYLENE	METAL DECIMAL ± .125" FRACTION ± 1/4" ANGLE ± 1°			SHIPPING WEIGHT: SEE NOTES	
±1% @ 68°F				FINISH:	



Den Hartog
INDUSTRIES, INC.

Ace Roto-Mold Injection Molding Blow Molding Sowjoy

4010 HOSPERS DRIVE S. BOX 425, HOSPERS, IOWA 51238-0425

DESCRIPTION	48 X 120 X 20 FLOAT	
SCALE	N.S.	PART NO. 48120-20