

© DEN HARTOG INDUSTRIES, INC.

Copyright. All information furnished within this document, electronic file or design correspondence is the property of Den Hartog Industries, Inc. and shall not be used, disclosed to others or copied without the expressed written consent of Den Hartog Industries, Inc.

4872-28

B

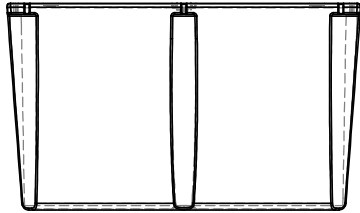
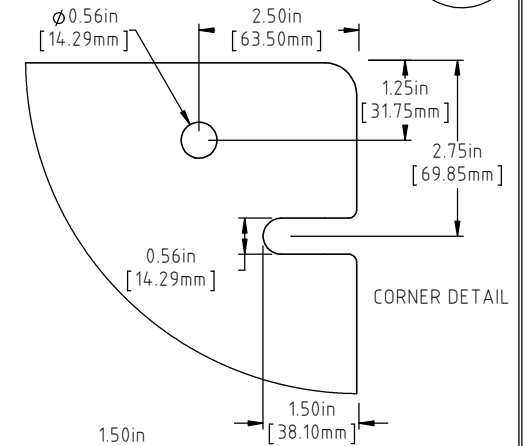
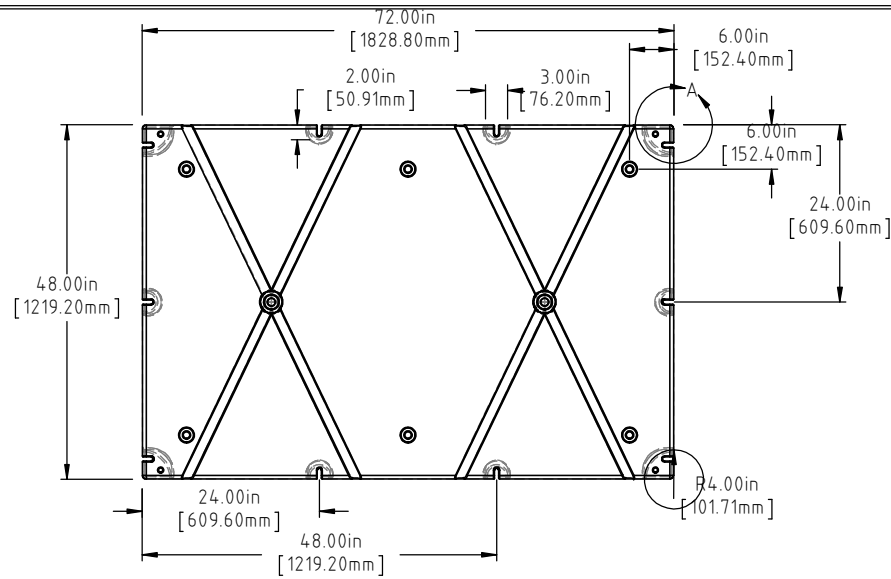

B

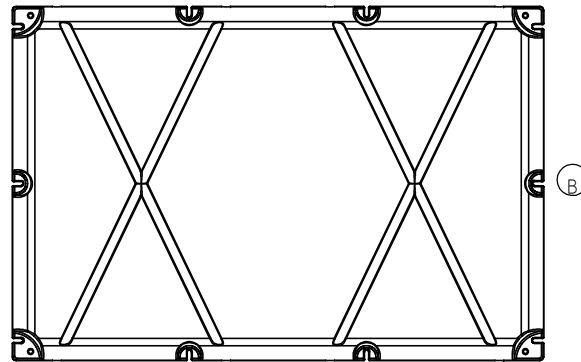
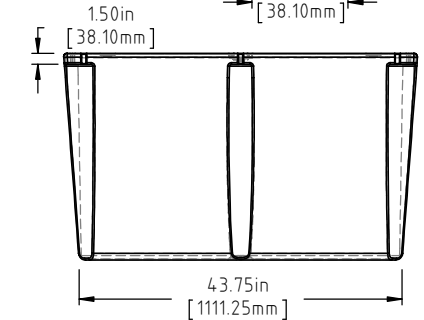
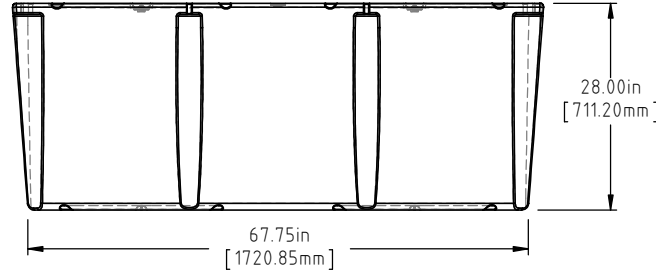

B

A

NOTE: BUOYANCY IS 2940 LBS.(1333.56 KG)

| | | | | | |
|---|---|--------------------------------------|------|-------------------------------------|--|
| B | BOTTOM/SIDE VIEWS ADDED TO PRINT. | ADH 12/4/14 | 2971 | DRAWN / DATE DHJ 8/14/07 | MATERIAL POLYETHYLENE |
| A | ADD BUOYANCY NOTE | ADH 6/25/12 | 2420 | APPRD. / DATE REH 10/3/07 | |
| REV | DESCRIPTION | BY / DATE | CCN | | |
| ALL DIMENSIONS ARE IN DECIMAL INCHES TOLERANCES UNLESS OTHERWISE SPECIFIED | | THIRD ANGLE PROJECTION ANSI 14.5M | | SHOT WEIGHT: 90 LBS. (40.82 KG.) | NOTES: 1.) AF 90 LBS. (40.82 KG.) 2.) FF 141 LBS. (63.96 KG.) 3.) 0.175 IN (4.44 mm) NOM. WALL |
| POLYETHYLENE | METAL DECIMAL ± .125" FRACTION ± 1/4" ANGLE ± 1° | | | SHIPPING WEIGHT: SEE NOTES | |
| ±1% @ 68°F | | | | FINISH: | |



Den Hartog
INDUSTRIES, INC.

Ace Roto-Mold Injection Molding Blow Molding Sowjoy

4010 HOSPERS DRIVE S. BOX 425, HOSPERS, IOWA 51238-0425

| | | |
|-------------|--------------------|------------------|
| DESCRIPTION | 48 x 72 x 28 FLOAT | |
| SCALE | N.S. | PART NO. 4872-28 |