

Copyright. All information furnished within this document, electronic file or design correspondence is the property of Den Hartog Industries, Inc. and shall not be used, disclosed to others or copied without the expressed written consent of Den Hartog Industries, Inc.

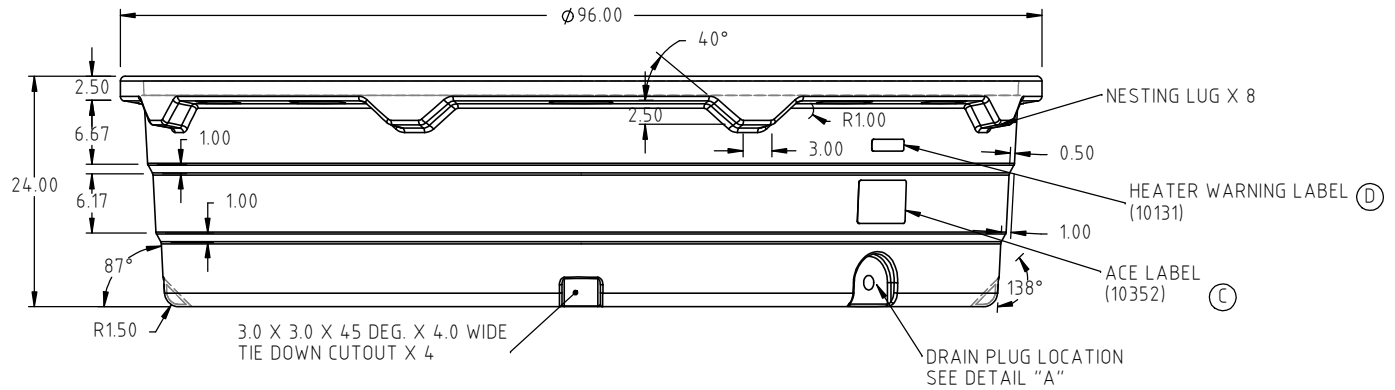
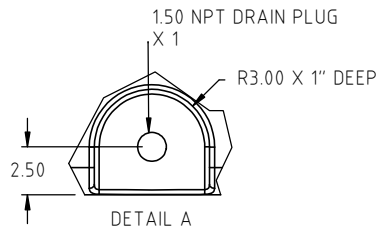
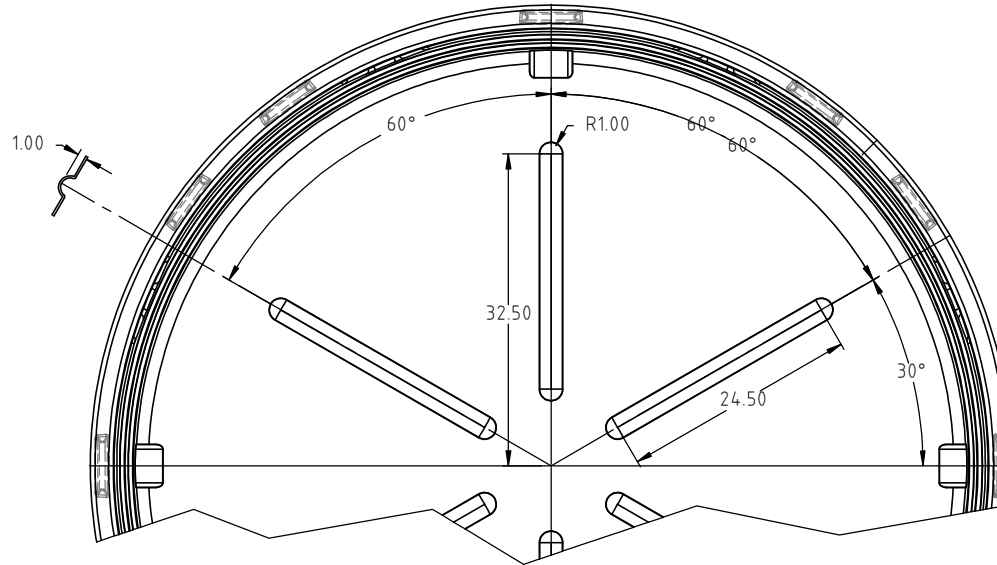

E	DRINKER CUTOUTS REMOVED	ADH 7/9/19	3811
D	SPRUCE GREEN WAS FOREST GREEN LABEL LOCATION CORRECTED	ADH 12/7/12	2539
C	LABEL NUMBER ADDED, DRAWING TEMPLATE UPDATED	ADH 8/31/09	1916
B	CAPACITY CORRECTED	10/03/01	
A	WAS 95 LB.		
REV	DESCRIPTION	BY / DATE	CCN

ACE R-82 STOCK TANK
10/2/98

MAX. CAPACITY - LEVEL = 610 U.S. GAL.

ALL DIMENSIONS ARE IN DECIMAL INCHES TOLERANCES UNLESS OTHERWISE SPECIFIED
POLYETHYLENE
±1% @ 68°F

THIRD ANGLE PROJECTION
ANSI 14.5M

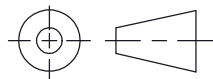

SHOT WEIGHT: 95 LBS
SHIPPING WEIGHT: 92 LBS
FINISH:

NOTES: (D)
1.) NOM. WALL = .220
2.) STD. COLOR TO BE SPRUCE GREEN



Den Hartog
INDUSTRIES, INC.

Ace Roto-Mold Injection Molding Blow Molding Blowjey

4010 HOSPERS DRIVE S. BOX 425, HOSPERS, IOWA 51238-0425

DESCRIPTION	ACE / R82 POLY STOCK TANK	
SCALE	N.S.	PART NO. ARM-10139