

Copyright. All information furnished within this document, electronic file or design correspondence is the property of Den Hartog Industries, Inc. and shall not be used, disclosed to others or copied without the expressed written consent of Den Hartog Industries, Inc.

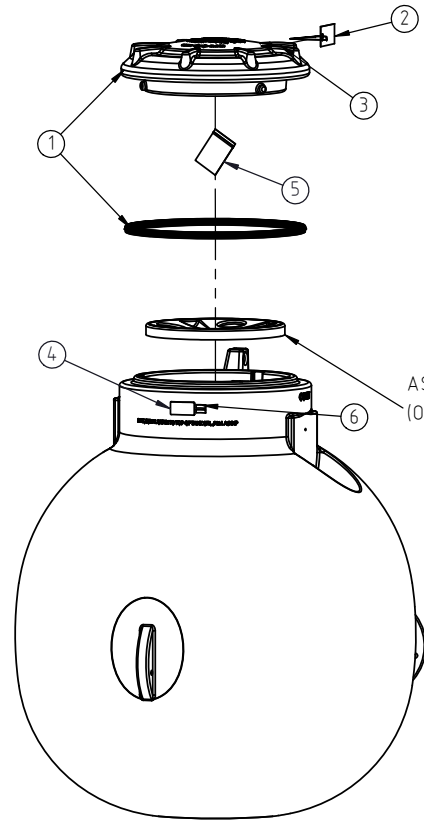

LIFTING LUGS 3 PLACES  
120" O.C.

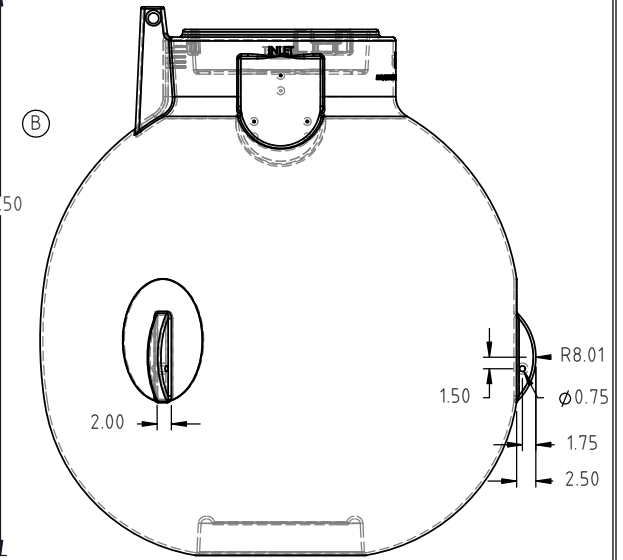
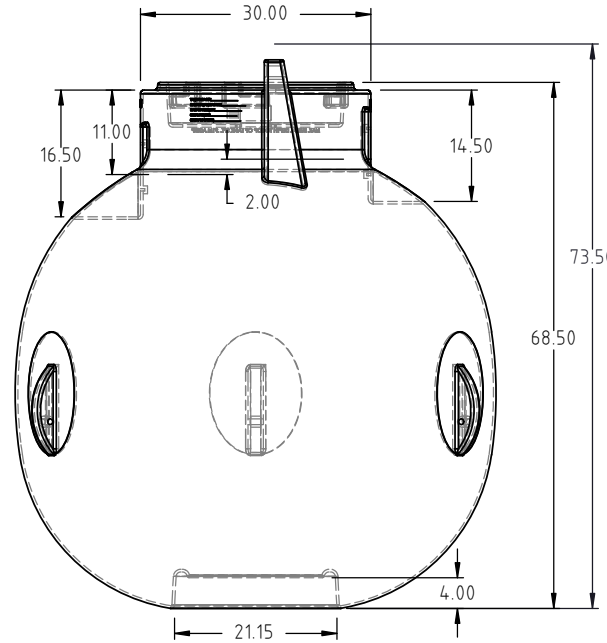
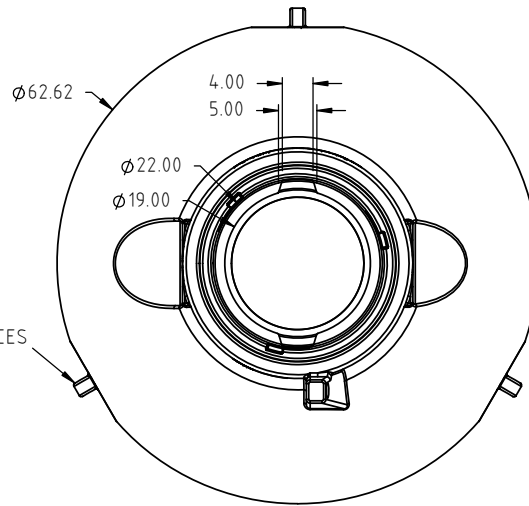

KEY	PART NUMBER	DESCRIPTION	QTY
1	AST19213	LID, 24" CISTERN WHT W/GASKET	1
2	11113	TAG, 6-1/4" X 3-1/8" TYVEK	1
3	19318	TIE STRAP, 14" NYLON BLACK	1
4	10357	LABEL, BARCODE 4" X 2"	1
5	19252	INSTRUCTION, SPHERICAL	1
6	14935	LABEL, PROP 65	1

C	PRINT LAYOUT UPDATED	ADH 7/18/19	3817	DRAWN / DATE	MATERIAL  POLYETHYLENE
B	ADD 10 LBS	DHJ 8/30/07		DHJ 9/19/06	
A	ADD 4 INCHES TO MOLD	DHJ 8/30/07		APPRD. / DATE REH 7/25/07	
REV	DESCRIPTION	BY / DATE	CCN		
ALL DIMENSIONS ARE IN DECIMAL INCHES TOLERANCES UNLESS OTHERWISE SPECIFIED		THIRD ANGLE PROJECTION ANSI 14.5M		SHOT WEIGHT: 180.00 LBS	NOTES: 1.) WHITE
POLYETHYLENE		METAL DECIMAL ± .125" FRACTION ± 1/4" ANGLE ± 1°		SHIPPING WEIGHT: 197.00 LBS	
±1% @ 68°F				FINISH:	



**Den Hartog**  
INDUSTRIES, INC.

Ace Roto-Mold Injection Molding Blow Molding Sowjoy

4010 HOSPERS DRIVE S. BOX 425, HOSPERS, IOWA 51238-0425

DESCRIPTION	525 GALLON CISTERN	
SCALE	N.S.	PART NO. AST-0525-1W