

Copyright. All information furnished within this document, electronic file or design correspondence is the property of Den Hartog Industries, Inc. and shall not be used, disclosed to others or copied without the expressed written consent of Den Hartog Industries, Inc.

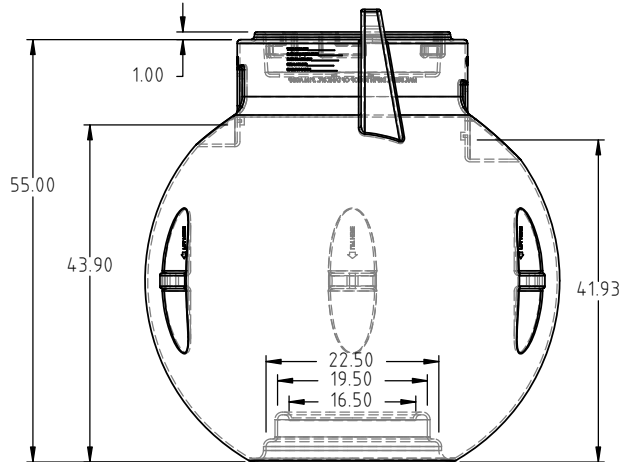

KEY	PART NUMBER	DESCRIPTION	QTY.
1	AST19213	LID, 24" CISTERN WHT W/GASKET	1
2	11113	TAG, 6-1/4" X 3-1/8" TYVEK	1
3	19318	TIE STRAP, 14" NYLON BLACK	1
4	10357	LABEL, BARCODE 4" X 2"	1
5	19255	INSTRUCTION, SPHERICAL	1
6	14935	LABEL, PROP 65	1

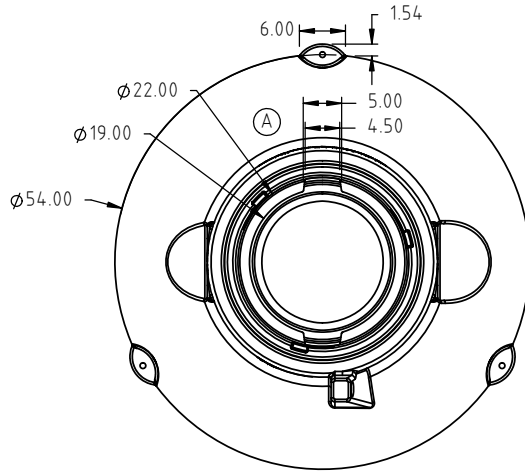
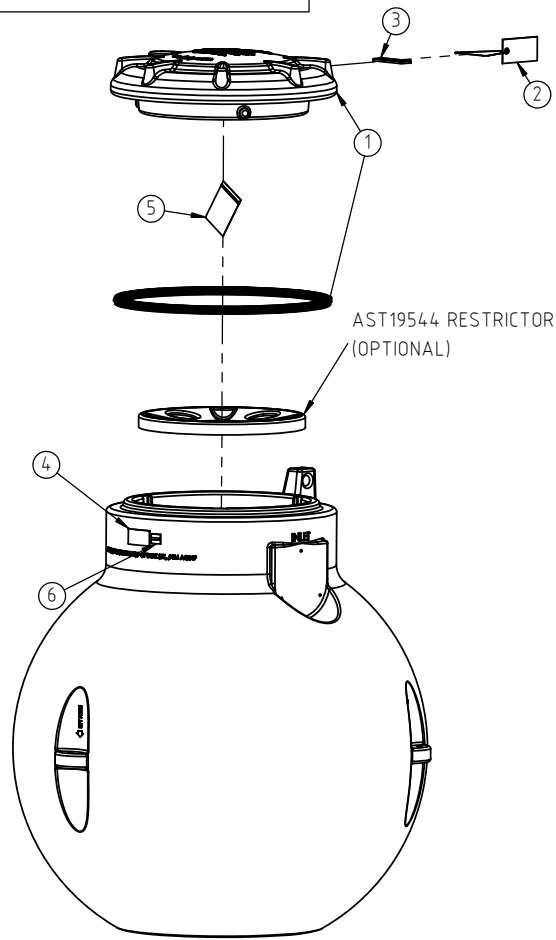
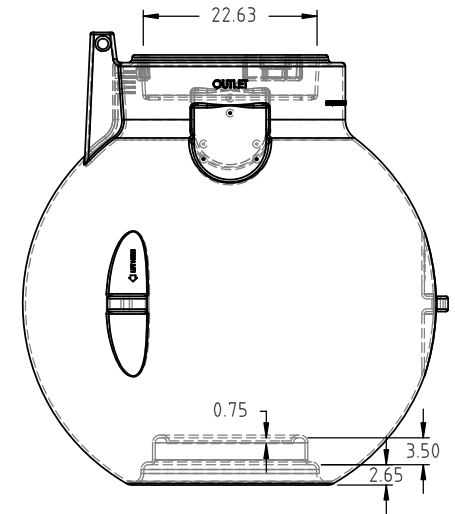

				DRAWN / DATE DHJ 3/17/04	MATERIAL OPTIONS (IN ORDER OF PREFERENCE): 13858
A	PRINT LAYOUT UPDATED.	ADH 7/18/19	3817	APPROD. / DATE ADH 7/18/19	
REV	DESCRIPTION	BY / DATE	CCN		
ALL DIMENSIONS ARE IN DECIMAL INCHES TOLERANCES UNLESS OTHERWISE SPECIFIED		THIRD ANGLE PROJECTION ANSI 14.5M		SHOT WEIGHT: 120.00 LBS	NOTES: 1.) WHITE
POLYETHYLENE		METAL DECIMAL ± .125" FRACTION ± 1/4" ANGLE ± 1°		SHIPPING WEIGHT: 137.00 LBS	
±1% @ 68°F				FINISH:	



Den Hartog
INDUSTRIES, INC.

Ace Roto-Mold Injection Molding Blow Molding Sowjoy

4010 HOSPERS DRIVE S. BOX 425, HOSPERS, IOWA 51238-0425

DESCRIPTION	325 GALLON CISTERN	
SCALE	N.S.	PART NO. AST-0325-1W