

TO INSURE UNIFORM GASKET  
INSTALLATION DEPTH USE  
ROLLER INSTALLATION TOOL

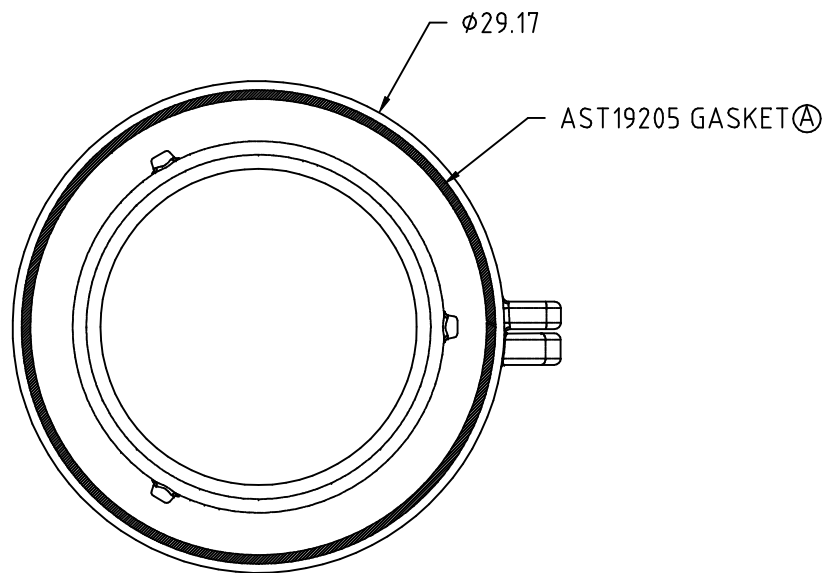

				DRAWN / DATE REH / 5/11/04
A	DRAWING INFORMATION UPDATED	ADH 1/11/08	CCN1561	APPRD. / DATE DHJ / 5/11/04
REV	DESCRIPTION	DATE	APPRD	

THIRD ANGLE PROJECTION  
ANSI 14.5M

MATERIAL  
10420 NATURAL

NOTES:  
 1. SHOT WEIGHT = 34 LB. 10420  
 2. SHIPPING WEIGHT = 35 LB.  
 3. WALL THICKNESS = .190



**Ace Roto-Mold**  
 A DIVISION OF DEN HARTOG INDUSTRIES, INC.  
 4010 HOSPERS DRIVE S. BOX 425, HOSPERS, IOWA 51238-0421

CLIENT / DESCRIPTION  
 CISTERN TANK EXTENSION ASSEMBLY

SCALE  
 N.S.

PART NO.  
 Ⓐ AST19214

ALL DIMENSIONS ARE IN DECIMAL INCHES  
 TOLERANCES UNLESS OTHERWISE SPECIFIED  
 ± 1% @ 68° F