

Copyright. All information furnished within this document, electronic file or design correspondence is the property of Den Hartog industries, Inc. and shall not be used, disclosed to others or copied without the expressed written consent of Den Hartog Industries, Inc.

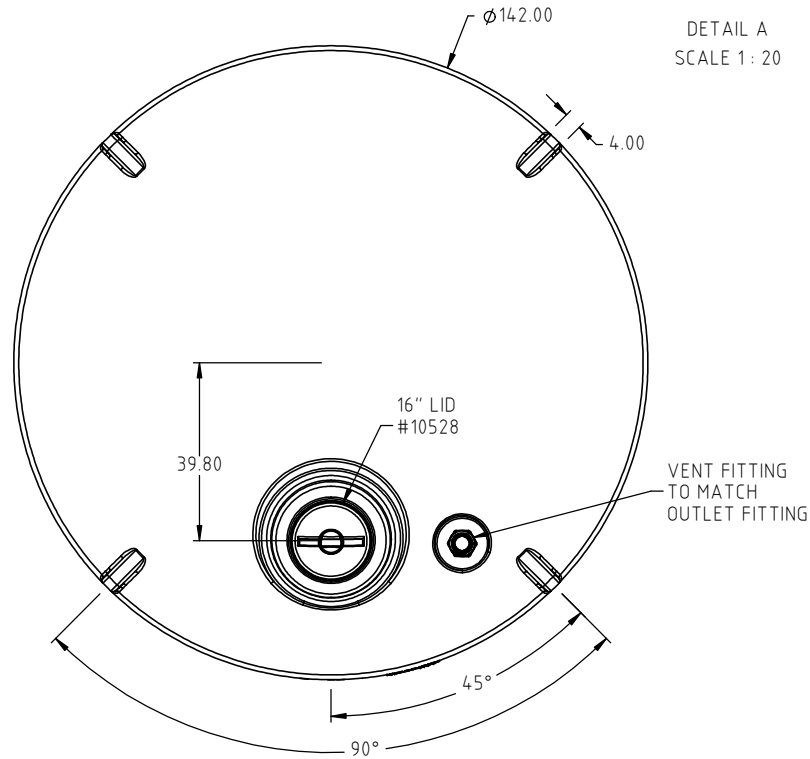

LIFTING LUG TYP. 4 PLACES

MOLD PARTING LINE SHOWN FOR REFERENCE ONLY

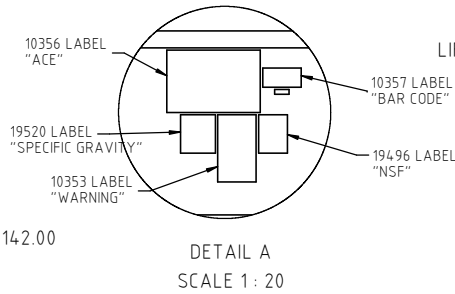
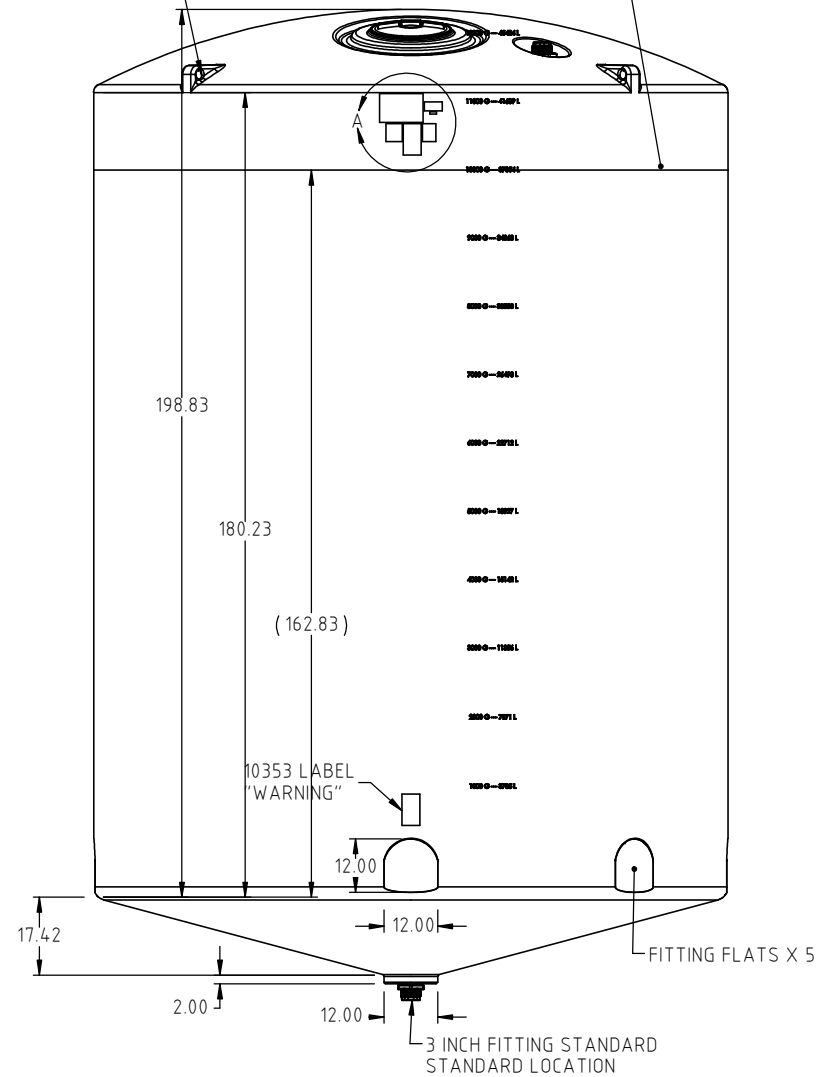

DRAWN / DATE ADH 2/28/2018	MATERIAL: 10538 2 MELT NATURAL RESIN
APPROD. / DATE BPL 6/9/2021	

SHOT WEIGHT: 3400.00 LBS	NOTES: 1.) WHITE, BLACK, OR YELLOW COLOR WALL THICKNESS AT FITTING: 1.39"
SHIPPING WEIGHT: 3402.00 LBS	
FINISH:	



Den Hartog INDUSTRIES, INC.

Ace Roto-Mold • Injection Molding • Blow Molding • Sowjoy
4010 HOSPERS DRIVE S. BOX 425, HOSPERS, IOWA 51238-0425

REV.	DESCRIPTION	BY	DATE	CCN
ALL DIMENSIONS ARE IN DECIMAL INCHES TOLERANCES UNLESS OTHERWISE SPECIFIED				
POLYETHYLENE ±1% @ 68°F		THIRD ANGLE PROJECTION ANSI 14.5M		
METAL DECIMAL ± .125" FRACTION ± 1/4" ANGLE ± 1°				

DESCRIPTION 12500 GALLON 15 DEGREE CONE BOTTOM TANK		SHEET 1 OF 1	
SCALE N.S.	PART NO. CB12500-142		