

Copyright. All information furnished within this document, electronic file or design correspondence is the property of Den Hartog industries, Inc. and shall not be used, disclosed to others or copied without the expressed written consent of Den Hartog Industries, Inc.

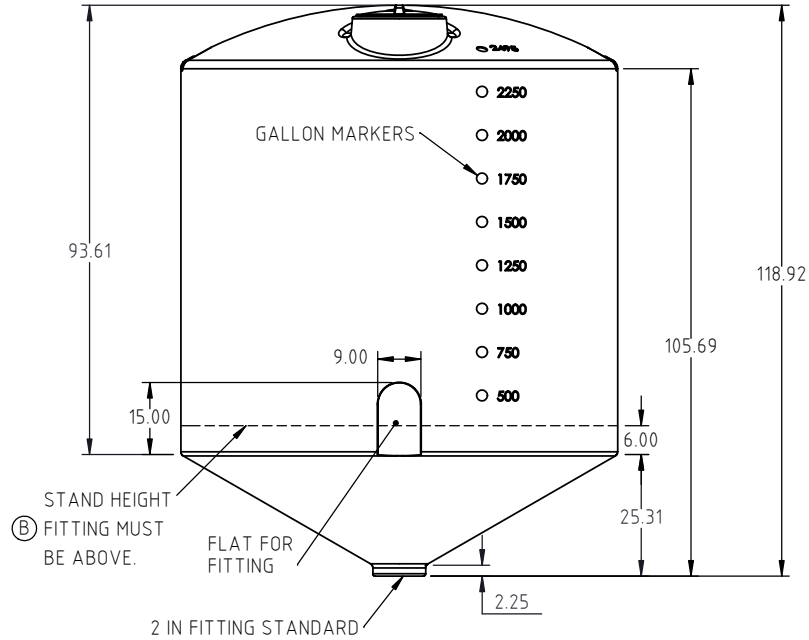

B	NOTE ADDED	ADH 11/28/19	3674	DRAWN / DATE DHJ 3/25/11	MATERIAL HDPE OR EQUIVALENT
A	WAS 90	DHJ 5/19/17	3385	APPRD. / DATE XXXX	
REV	DESCRIPTION	BY / DATE	CCN		
ALL DIMENSIONS ARE IN DECIMAL INCHES TOLERANCES UNLESS OTHERWISE SPECIFIED		THIRD ANGLE PROJECTION ANSI 14.5M		SHOT WEIGHT: 485.00 LBS.	NOTES:
POLYETHYLENE		METAL DECIMAL ± .125" FRACTION ± 1/4" ANGLE ± 1°		SHIPPING WEIGHT: 487.00 LBS.	
±1% @ 68°F				FINISH:	

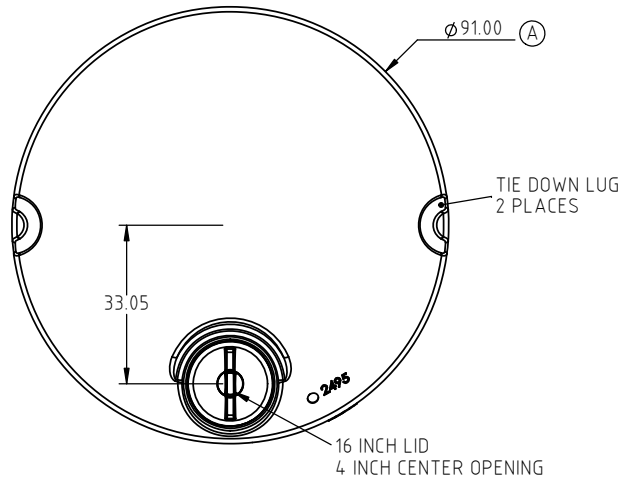

Den Hartog
INDUSTRIES, INC.

Ace Roto-Mold Injection Molding Blow Molding Sowjoy

4010 HOSPERS DRIVE S. BOX 425, HOSPERS, IOWA 51238-0425

DESCRIPTION 2495 GALLON CONE BOTTOM TANK 30 DEG.	
SCALE N.S.	PART NO. CB2495-90