

Ⓐ 16" LID ASSEMBLY STANDARD (P.N. 10528)
 22" LID ASSEMBLY OPTIONAL (P.N. 10530)

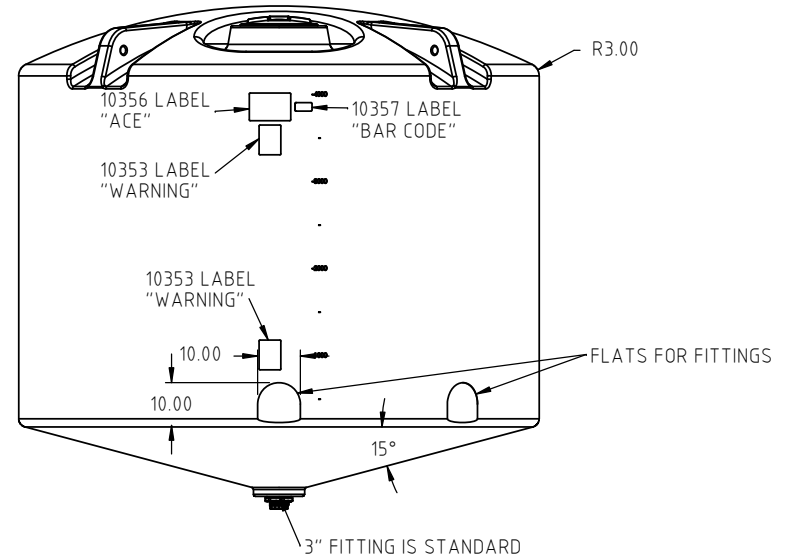

				DRAWN / DATE DHJ 1/26/12	MATERIAL
A	RIB REMOVED FROM PART	DHJ 9/20/19	3849	APPRD. / DATE REH 2/11/14	10538
REV	DESCRIPTION	BY / DATE	CCN		
ALL DIMENSIONS ARE IN DECIMAL INCHES TOLERANCES UNLESS OTHERWISE SPECIFIED		THIRD ANGLE PROJECTION ANSI 14.5M		SHOT WEIGHT: 1100 LBS	NOTES: 1.) 0.52" NOM. WALL
POLYETHYLENE		METAL DECIMAL ± .125" FRACTION ± 1/4" ANGLE ± 1°		SHIPPING WEIGHT: 1102 LBS.	
±1% @ 68°F				FINISH:	

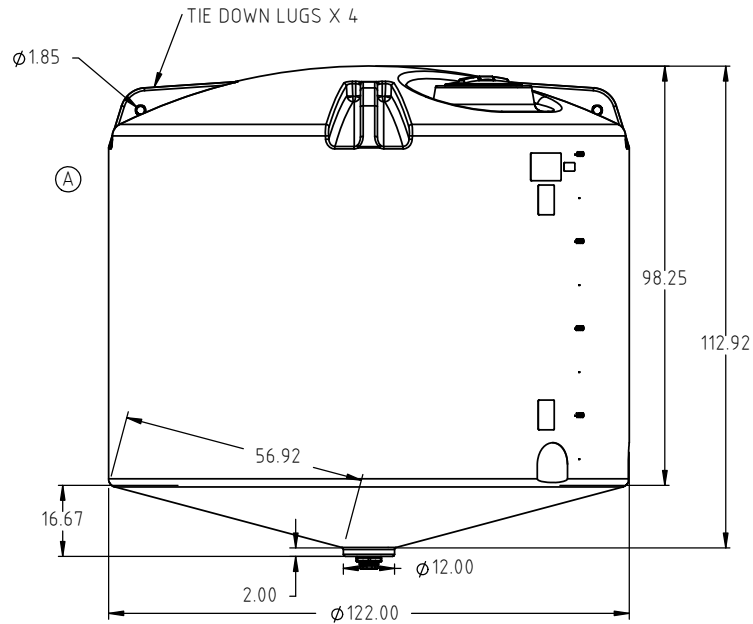

Den Hartog
INDUSTRIES, INC.

Ace Roto-Mold Injection Molding Blow Molding Sowjoy

4010 HOSPERS DRIVE S. BOX 425, HOSPERS, IOWA 51238-0425

DESCRIPTION	4200 GALLON 122" X 15 DEG. CONE BOTTOM TANK	
SCALE	N.S.	PART NO. CB4200-122