

© DEN HARTOG INDUSTRIES, INC.

Copyright. All information furnished within this document, electronic file or design correspondence is the property of Den Hartog Industries, Inc. and shall not be used, disclosed to others or copied without the expressed written consent of Den Hartog Industries, Inc.

CB8250-122

C

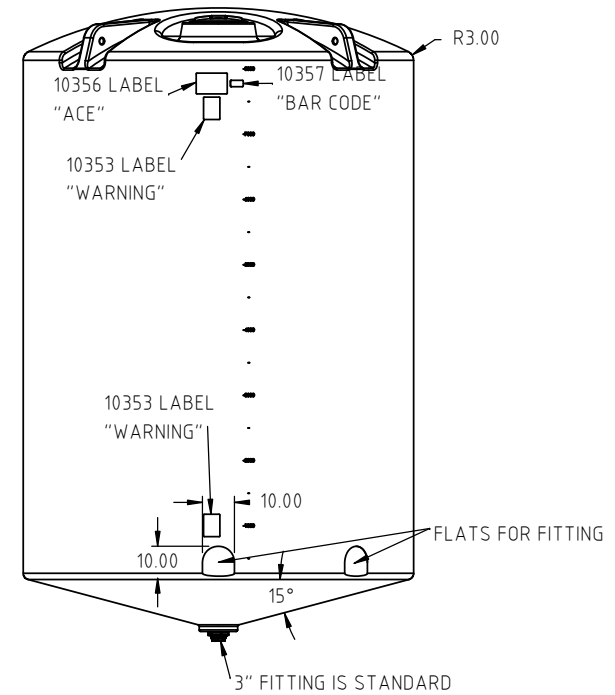
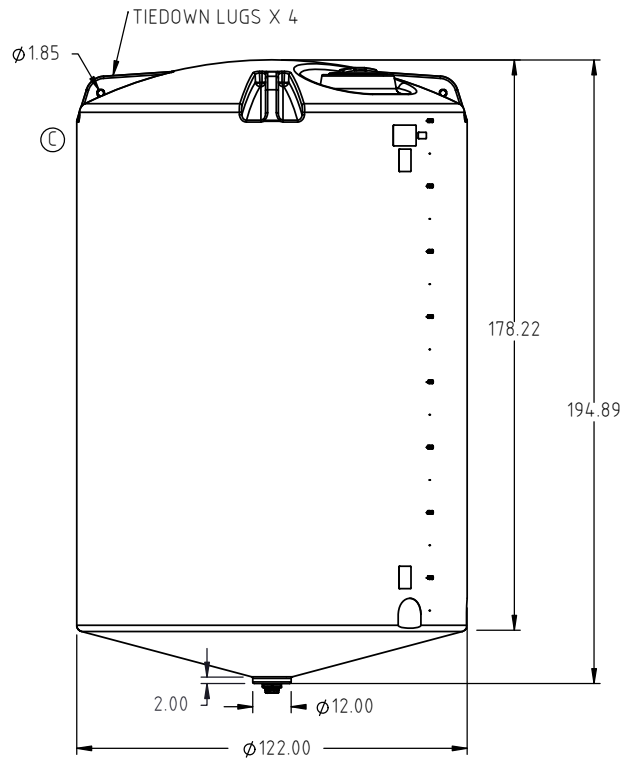
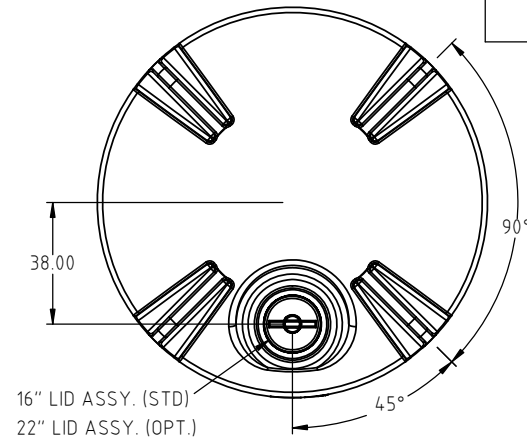

C	RIB REMOVED FROM PART	DHJ 9/20/19	3849	DRAWN / DATE	MATERIAL 10538 2 MELT
B	CHANGED STANDARD FITTING FROM 2" TO 3"	DHJ 3/31/10	2013	DHJ 1/16/07	
A	CHANGE PART NUMBER	DHJ 5/7/09		APPRD. / DATE	
REV	DESCRIPTION	BY / DATE	CCN	REH 4/18/07	
ALL DIMENSIONS ARE IN DECIMAL INCHES TOLERANCES UNLESS OTHERWISE SPECIFIED		THIRD ANGLE PROJECTION ANSI 14.5M		SHOT WEIGHT:	NOTES: 1.) WHITE, BLACK, OR YELLOW COLOR
POLYETHYLENE		METAL DECIMAL ± .125" FRACTION ± 1/4" ANGLE ± 1°		SHIPPING WEIGHT:	
±1% @ 68°F				FINISH:	



# Den Hartog

INDUSTRIES, INC.

Ace Roto-Mold Injection Molding Blow Molding Sowjoy

4010 HOSPERS DRIVE S. BOX 425, HOSPERS, IOWA 51238-0425

DESCRIPTION		8250 GALLON 15° CONE BOTTOM TANK	
SCALE	N.S.	PART NO.	CB8250-122