

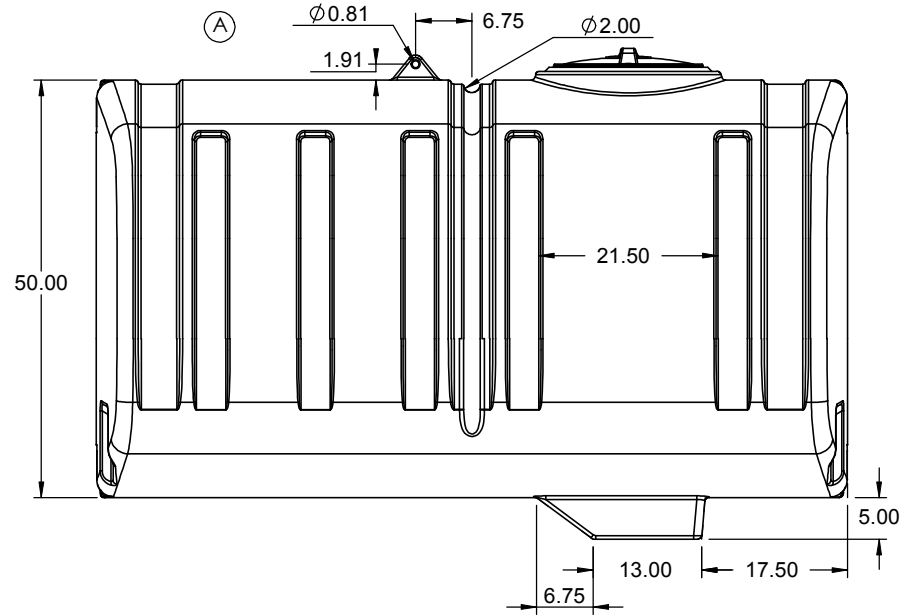

Copyright. All information furnished within this document, electronic file or design correspondence is the property of Den Hartog industries, Inc. and shall not be used, disclosed to others or copied without the expressed written consent of Den Hartog Industries, Inc.

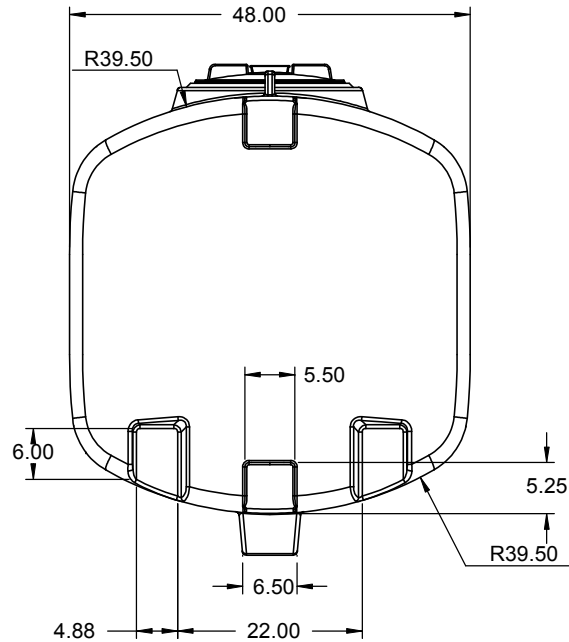
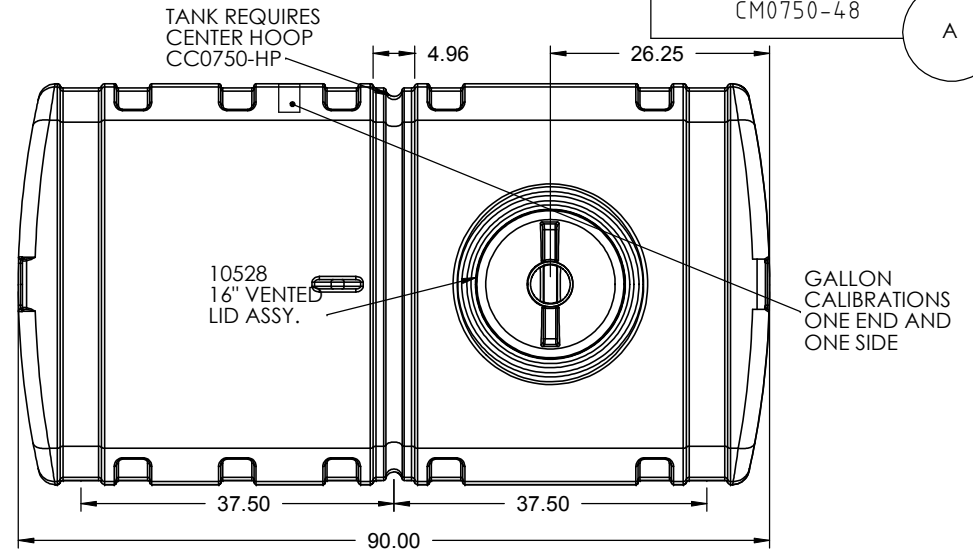
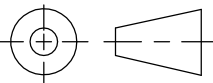

				DRAWN / DATE ADH 12/1/08	MATERIAL 1.) NATURAL=10538	 <p>Den Hartog INDUSTRIES, INC.</p> <p>Ace Roto-Mold Injection Molding Blow Molding Sowjoy 4010 HOSPERS DRIVE S. BOX 425, HOSPERS, IOWA 51238-0421</p>
A	LIFTING LUG DETAILS ADDED	REH	1846	APPRD. / DATE REH 12/15/08	2.) YELLOW=10600	
REV	DESCRIPTION	BY / DATE	CCN	SHOT WEIGHT: 260 LBS	NOTES: 1.) .375 WALL	DESCRIPTION 750 GALLON CROP CARE TANK
ALL DIMENSIONS ARE IN DECIMAL INCHES TOLERANCES UNLESS OTHERWISE SPECIFIED		THIRD ANGLE PROJECTION ANSI 14.5M		SHIPPING WEIGHT: 262 LBS	FINISH:	SCALE N.S.
POLYETHYLENE ±1% @ 68°F						PART NO. CM0750-48
METAL DECIMAL ± .125" FRACTION ± 1/4" ANGLE ± 1°						