

© DEN HARTOG INDUSTRIES, INC.

Copyright. All information furnished within this document, electronic file or design correspondence is the property of Den Hartog industries, Inc. and shall not be used, disclosed to others or copied without the expressed written consent of Den Hartog Industries, Inc.

DC-2ST-WE

B

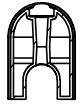

SECTION A-A

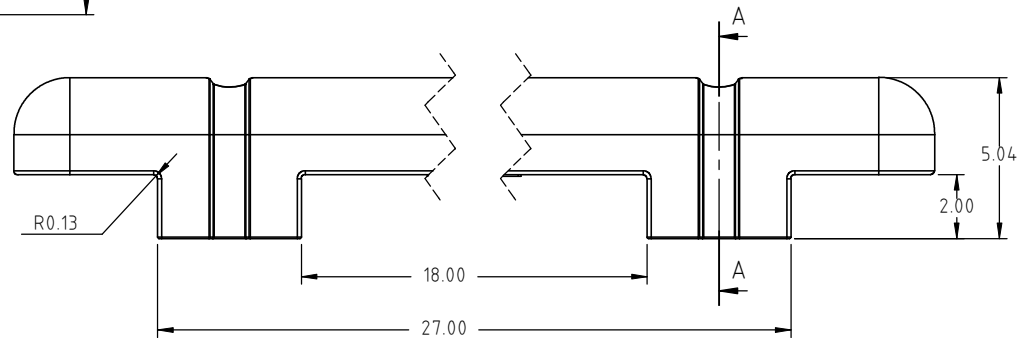
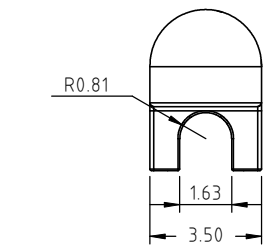
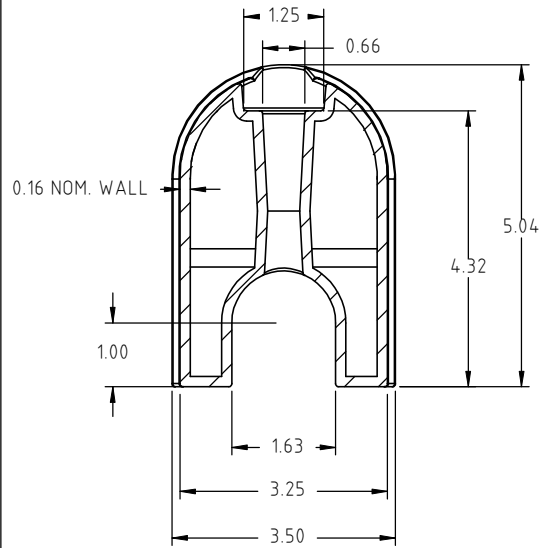
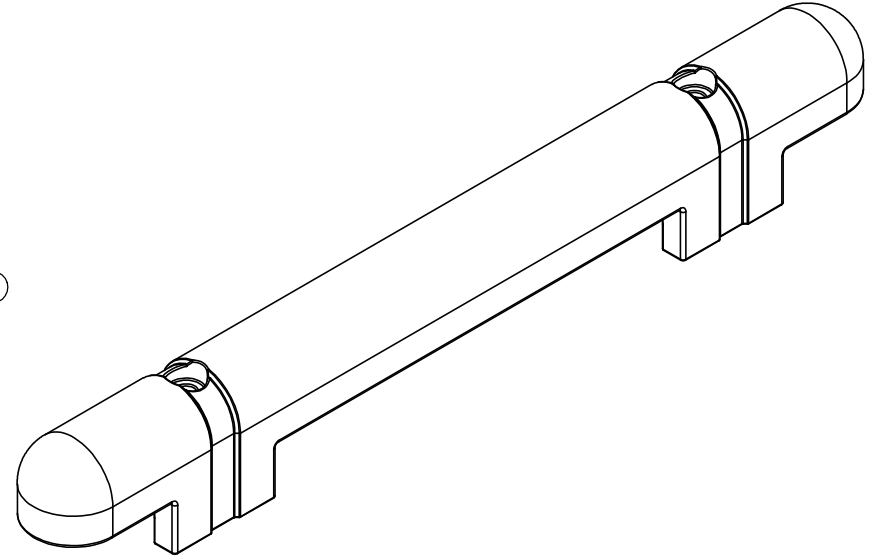
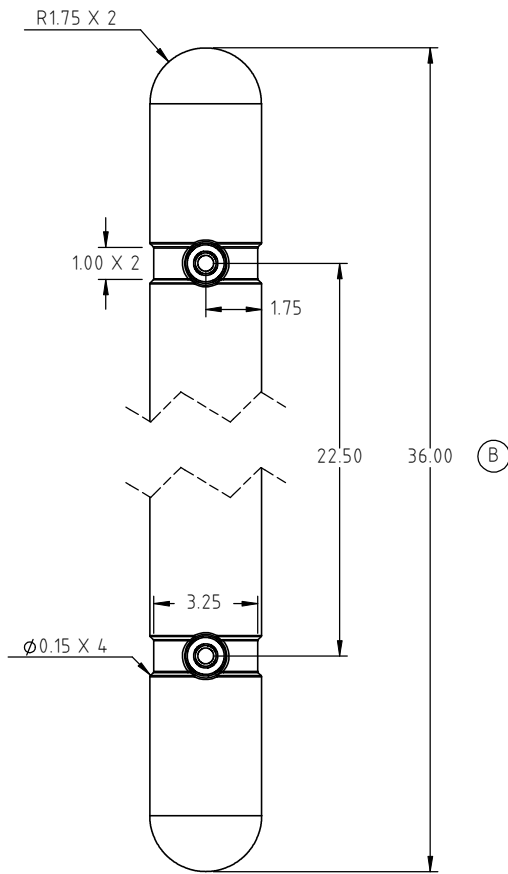

B	LENGTH WAS 24"	REH/10/21/10	2105	DRAWN / DATE	MATERIAL
A	MATERIAL/ADDRESS UPDATED	ADH 12/18/07	1275	ADH 10/20/10	FLEX MU736-00 OR EQUAL EVA
REV	DESCRIPTION	BY / DATE	CCN	APPRD. / DATE	FIRM MOBIL 135 OR EQUAL
				REH 10/21/10	
ALL DIMENSIONS ARE IN DECIMAL INCHES TOLERANCES UNLESS OTHERWISE SPECIFIED		THIRD ANGLE PROJECTION ANSI 14.5M		SHOT WEIGHT:	NOTES:
POLYETHYLENE		METAL DECIMAL ± .125" FRACTION ± 1/4" ANGLE ± 1°		2.7 LB.	1.) WHITE OR YELLOW COLOR
±1% @ 68°F				SHIPPING WEIGHT:	2.) NOM. WALL @ .160
				FINISH:	3.) ADD U.V. INHIBITOR TO EVA RESIN MIX



**Den Hartog**  
INDUSTRIES, INC.

Acro Roto-Mold Injection Molding Blow Molding Sowjoy

4010 HOSPERS DRIVE S. BOX 425, HOSPERS, IOWA 51238-0425

DESCRIPTION	NO. 2 ROUND CUSHION X 36" LONG	
SCALE	N.S.	PART NO. DC-2ST-WE