

ALL RADII .13
UNLESS SPECIFIED

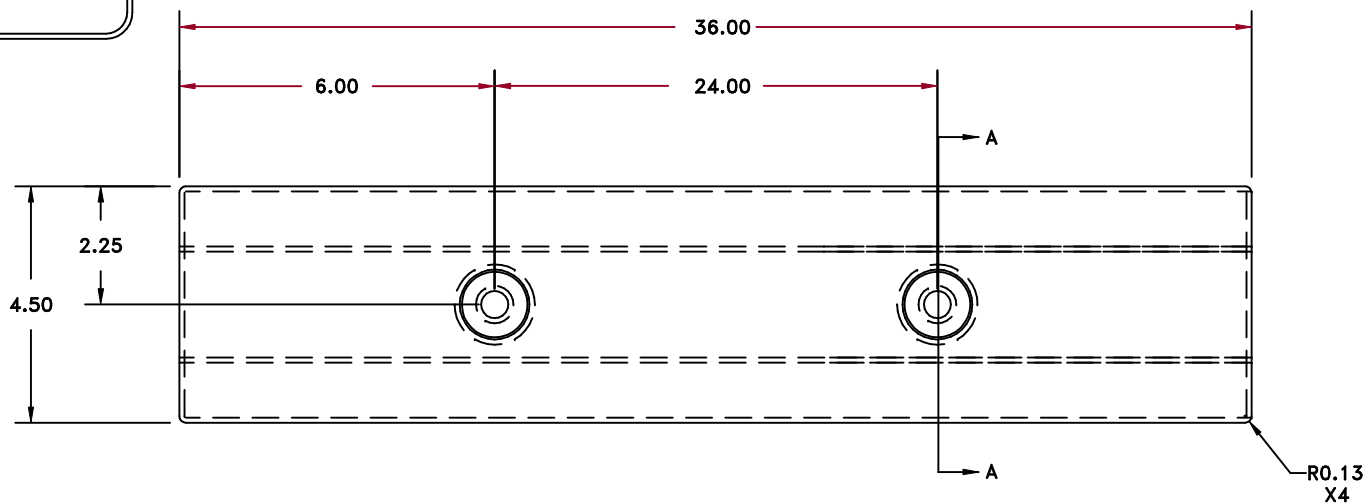
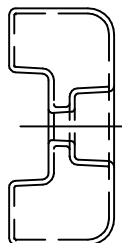

REV	DESCRIPTION	DATE	APPRD
A	MATERIAL/ADDRESS UPDATED	CCN1275	ADH 12/19/07

DRAWN / DATE	MATERIAL / SHOT WEIGHT
REH/11/20/97	FLEX \odot MU736-00 OR EQUAL EVA \bullet 2.2 LB.
APPRD. / DATE	FIRM \odot MOBIL 135 OR EQUAL \bullet 2.2 LB.
REH/11/20/97	

NOTES:
 1. NOM. WALL \bullet .150
 2. COLOR- SEE SCHEDULE
 3. ADD U.V. INHIBITOR TO EVA RESIN MIX

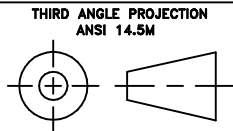

ALL DIMENSIONS ARE IN DECIMAL INCHES
 TOLERANCES UNLESS OTHERWISE SPECIFIED
 $\pm .060$ EXCEPT HOLES $\bullet \pm .015$

ACE ROTO-MOLD

4010 HOSPERS DRIVE S. BOX 425, HOSPERS, IOWA 51238-0421

CLIENT / DESCRIPTION

ACE NO. 7 DOCK CUSHION X 3 FT.

SCALE
DNS

PART NO.
DC-7ST-WE