

© DEN HARTOG INDUSTRIES, INC.

Copyright. All information furnished within this document, electronic file or design correspondence is the property of Den Hartog industries, Inc. and shall not be used, disclosed to others or copied without the expressed written consent of Den Hartog Industries, Inc.

STANDARD TANK ASSEMBLY

IMPORTANT!
 NEVER FILL ABOVE THE ADVERTISED CAPACITY OF TANK.
 FAILURE TO HEED MAY EXCEED THE RATED CAPACITY OF THE OUTER CONTAINMENT TANK.

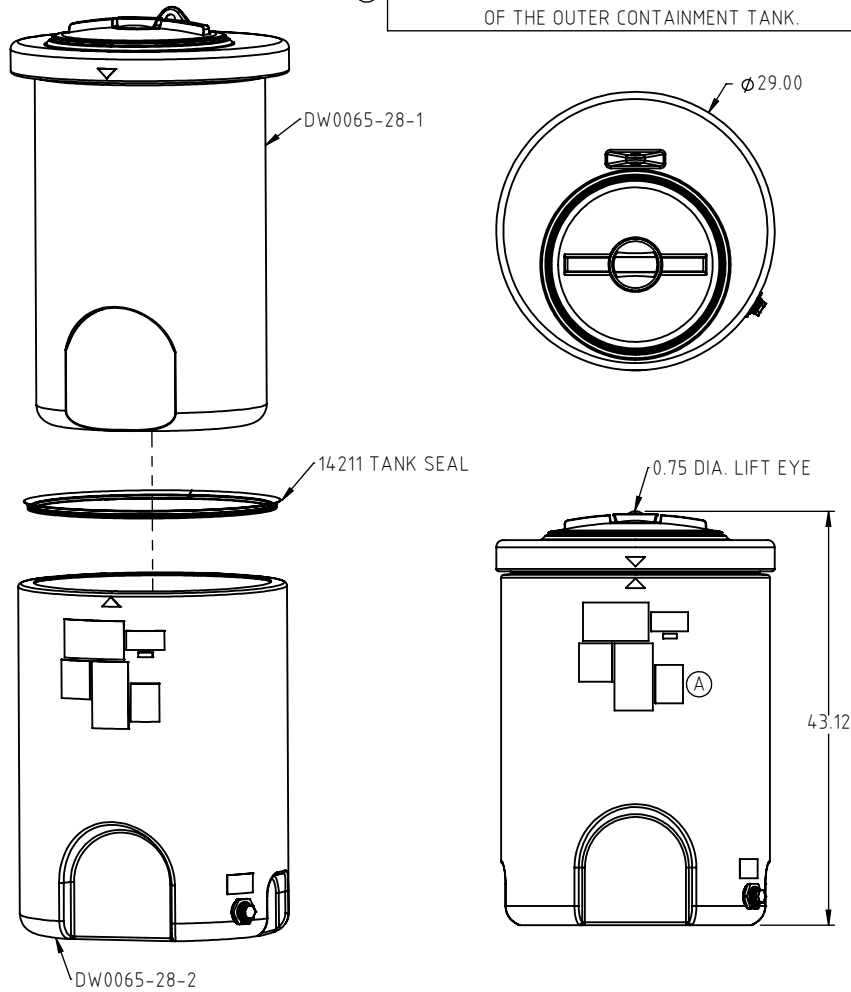

TANK ASSEMBLY WITH OPTIONAL 1" FITTING

DW0065-28

B

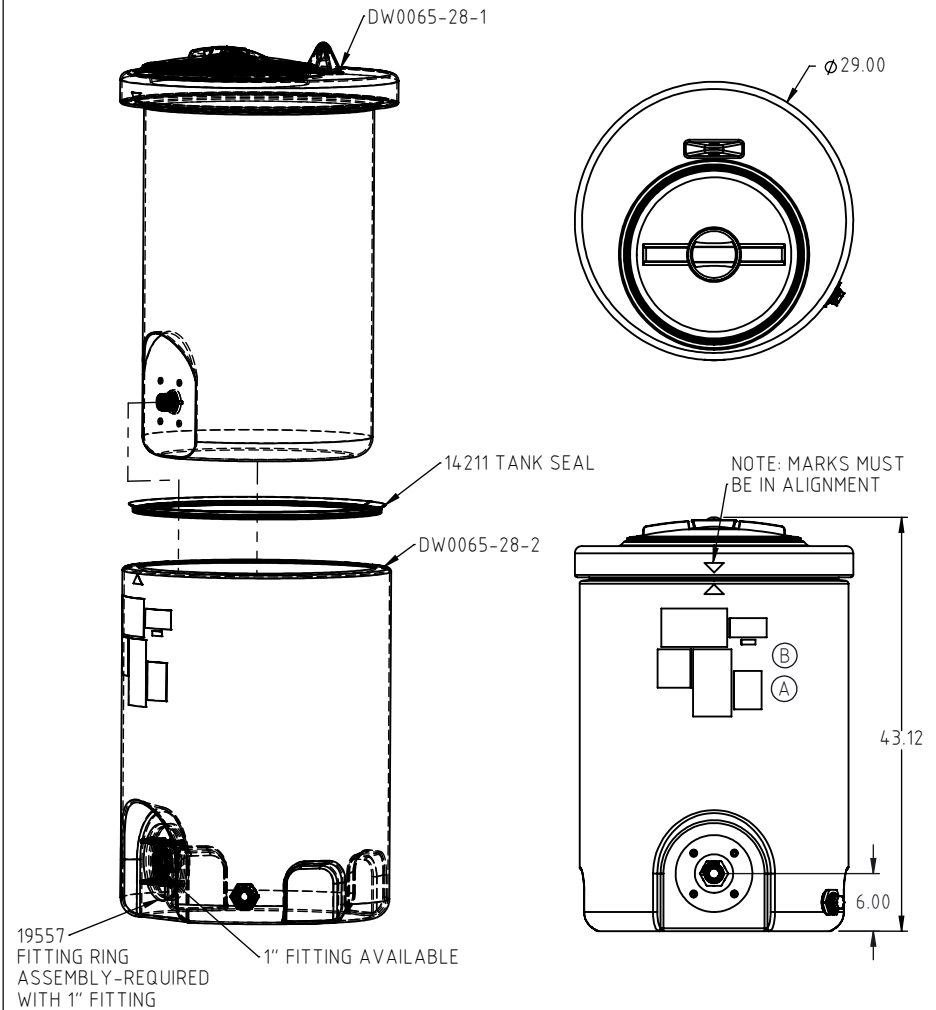

B	REMOVE 14234 LABEL AND NOTE	BES	1/27/23	4380	DRAWN / DATE	MATERIAL :
A	NOTICE AND NSF LABEL ADDED	ADH	2/14/18	3508	ADH 8/27/2014	SEE COMPONENTS
REV.	DESCRIPTION	BY	DATE	CCN	REH 10/20/2014	
ALL DIMENSIONS ARE IN DECIMAL INCHES TOLERANCES UNLESS OTHERWISE SPECIFIED					SHOT WEIGHT:	NOTES:
THIRD ANGLE PROJECTION ANSI 14.5M					SHIPPING WEIGHT: 50 LBS.	(B)
POLYETHYLENE					FINISH:	
METAL DECIMAL ± .125" FRACTION ± 1/4" ANGLE ± 1°						
±1% @ 68°F						



**Den Hartog
INDUSTRIES, INC.**

Ace Roto-Mold • Injection Molding • Blow Molding • Sowjoy
 4010 HOSPERS DRIVE S. BOX 425, HOSPERS, IOWA 51238-0425

DESCRIPTION 65 GALLON DUALLINE TANK ASSEMBLY		
SCALE N.S.	PART NO. DW0065-28	SHEET 1 OF 1