

© DEN HARTOG INDUSTRIES, INC.

Copyright. All information furnished within this document, electronic file or design correspondence is the property of Den Hartog Industries, Inc. and shall not be used, disclosed to others or copied without the expressed written consent of Den Hartog Industries, Inc.

STANDARD TANK ASSEMBLY

**IMPORTANT!**

NEVER FILL ABOVE THE ADVERTISED CAPACITY OF TANK. FAILURE TO HEED MAY EXCEED THE RATED CAPACITY OF THE OUTER CONTAINMENT TANK.

TANK ASSEMBLY WITH OPTIONAL FITTING

DW1000-77

C

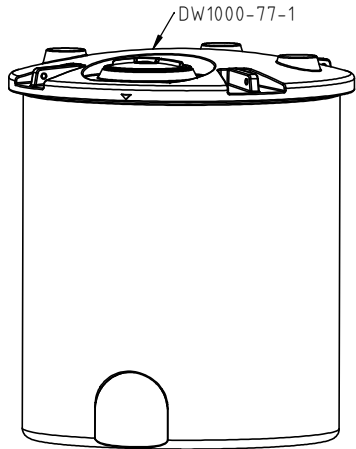

3 X 7.5" DIA. FITTING FLATS ON TANK TOP FOR UTILITIES

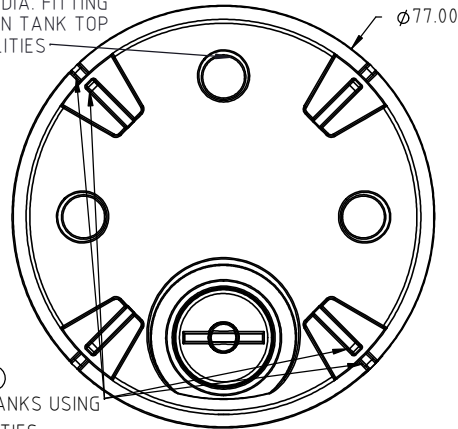

SECURE TANKS USING 14588 ZIP TIES X 2

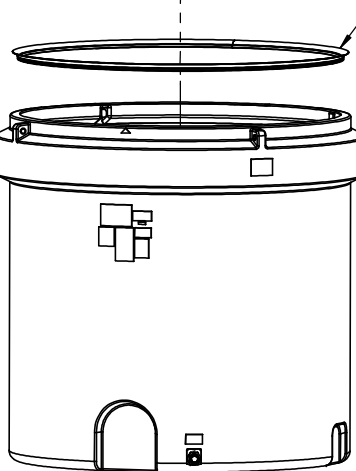

14214 TANK SEAL

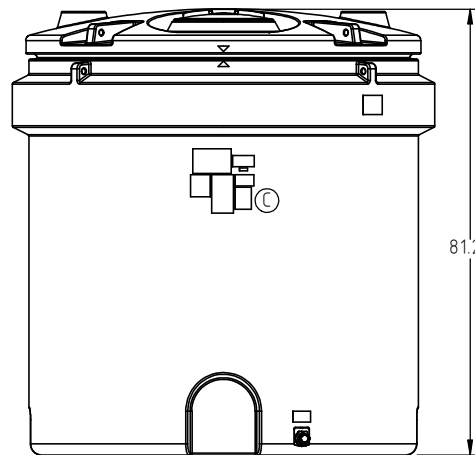

DW1000-77-2

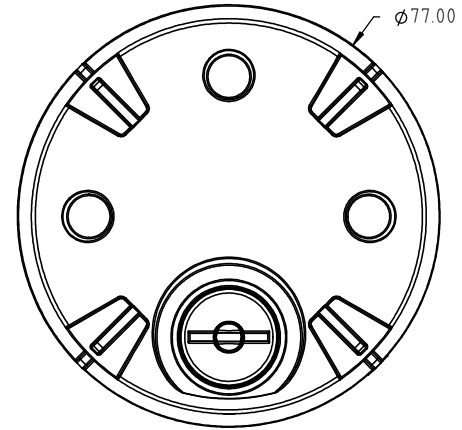
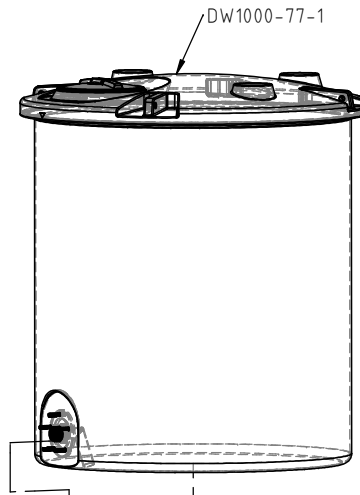

14214 TANK SEAL

NOTE: MARKS MUST BE IN ALIGNMENT.

19563 FITTING RING ASSEMBLY-REQUIRED WITH FITTING

2" FITTING AVAILABLE (A)

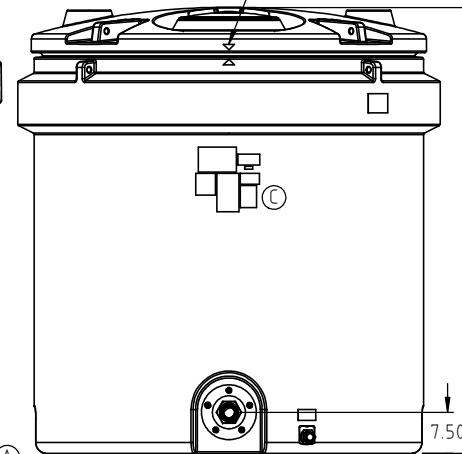

C	NOTICE AND NSF LABEL ADDED	ADH 2/15/18	3508	DRAWN / DATE	MATERIAL  SEE NOTE 1.
B	ZIP TIES ADDED TO ASSEMBLIES	ADH 11/8/16	3315	ADH 8/7/14	
A	FITTING LISTED ON PRINT STANDARDIZED.	ADH 10/15/15	3141	APPRO. / DATE	
REV	DESCRIPTION	BY / DATE	CCN	REH 8/22/14	
ALL DIMENSIONS ARE IN DECIMAL INCHES TOLERANCES UNLESS OTHERWISE SPECIFIED		THIRD ANGLE PROJECTION ANSI 14.5M		SHOT WEIGHT:	NOTES: 1.) REFERENCE COMPONENT PRINTS FOR DETAILS 2.) PATENT 9,162,816
POLYETHYLENE ±1% @ 68°F		METAL DECIMAL ± .125" FRACTION ± 1/4" ANGLE ± 1°		SHIPPING WEIGHT: STANDARD = 522 LBS.	
		FINISH:			



**Den Hartog**  
INDUSTRIES, INC.

Acra Roto-Mold Injection Molding Blow Molding Sowjoy

4010 HOSPERS DRIVE S. BOX 425, HOSPERS, IOWA 51238-0425

DESCRIPTION		1000 GALLON DUAL LINE™ TANK ASSEMBLY	
SCALE	N.S.	PART NO.	DW1000-77