

© DEN HARTOG INDUSTRIES, INC.

Copyright. All information furnished within this document, electronic file or design correspondence is the property of Den Hartog Industries, Inc. and shall not be used, disclosed to others or copied without the expressed written consent of Den Hartog Industries, Inc.

STANDARD TANK ASSEMBLY

IMPORTANT!
NEVER FILL ABOVE THE ADVERTISED CAPACITY OF TANK.
FAILURE TO HEED MAY EXCEED THE RATED CAPACITY
OF THE OUTER CONTAINMENT TANK.

TANK ASSEMBLY WITH
OPTIONAL FITTING

DW1500-77

D

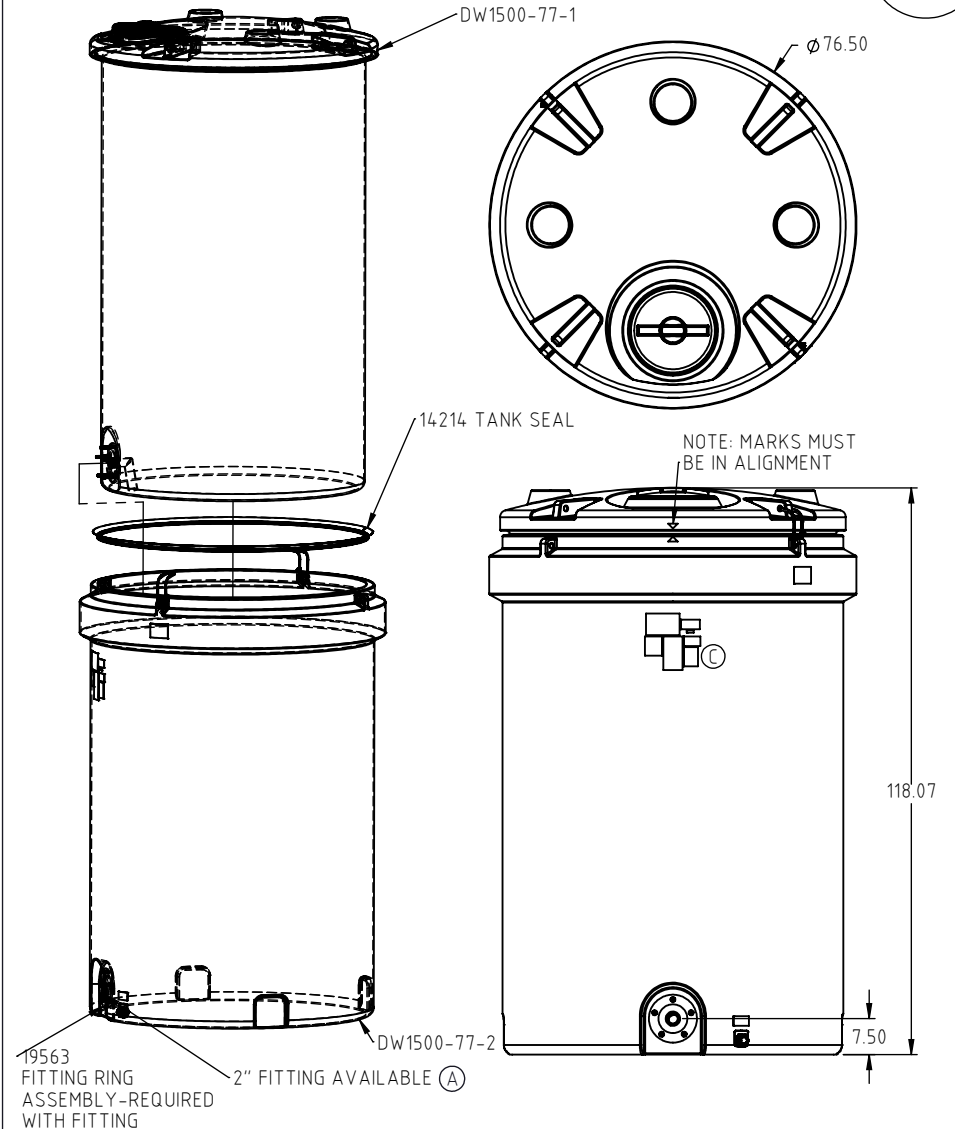
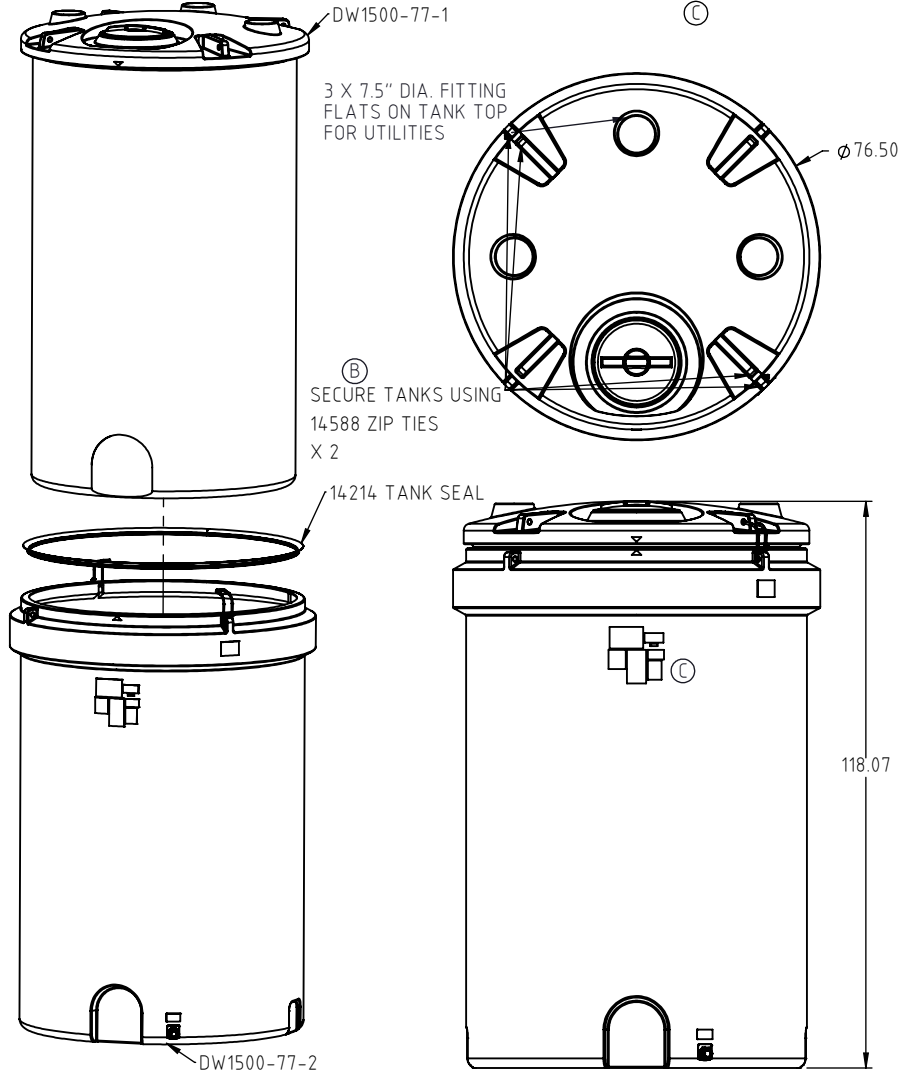

D	SHIPPING WEIGHT WAS 673 NOW 680	BES	3/6/2023	4396	DRAWN / DATE	MATERIAL :
C	NOTICE AND NSF LABEL ADDED	ADH	2/15/18	3508	ADH 8/8/2014	SEE COMPONENTS
B	ZIP TIES ADDED TO ASSEMBLIES	ADH	11/8/16	3315	APPRD. / DATE	
REV.	DESCRIPTION	BY	DATE	CCN	REH 8/22/2014	
ALL DIMENSIONS ARE IN DECIMAL INCHES TOLERANCES UNLESS OTHERWISE SPECIFIED		THIRD ANGLE PROJECTION ANSI 14.5M		SHOT WEIGHT:		NOTES:
POLYETHYLENE		METAL		SHIPPING WEIGHT:		PATENT 9,162,816
±1% @ 68°F		DECIMAL ± .125" FRACTION ± 1/4" ANGLE ± 1°		D STANDARD 680 LBS		
		FINISH:				



**Den Hartog
INDUSTRIES, INC.**

Ace Roto-Mold • Injection Molding • Blow Molding • Sowjoy
4010 HOSPERS DRIVE S. BOX 425, HOSPERS, IOWA 51238-0425

DESCRIPTION 1500 GALLON DUALLINE TANK ASSEMBLY		
SCALE N.S.	PART NO. DW1500-77	SHEET. 1 OF 1