

Copyright. All information furnished within this document, electronic file or design correspondence is the property of Den Hartog Industries, Inc. and shall not be used, disclosed to others or copied without the expressed written consent of Den Hartog Industries, Inc.

**IMPORTANT!**  
NEVER FILL ABOVE THE ADVERTISED CAPACITY OF TANK  
FAILURE TO HEED MAY EXCEED THE RATED CAPACITY  
OF THE OUTER CONTAINMENT TANK.

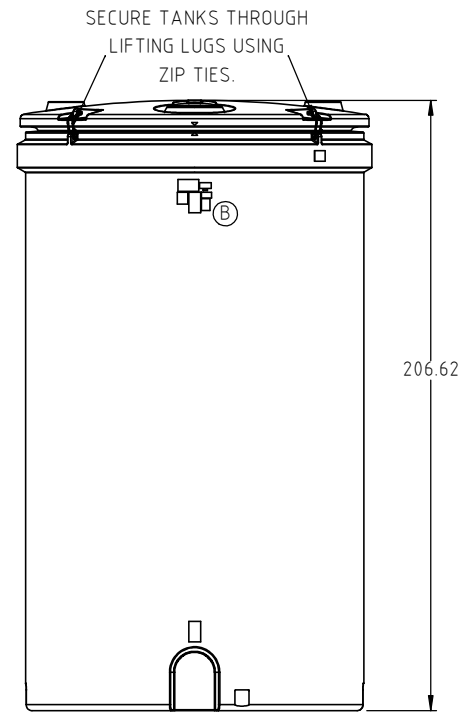

|   |   |                                      |      |  |   |
|---|---|--------------------------------------|------|--|---|
| B   | 19496 LABEL ADDED   | ADH 2/15/18                          | 3508 | DRAWN / DATE<br>ADH 1/26/15                              | MATERIAL<br><br>SEE NOTE 1  |
| A   | SHIPPING WEIGHT UPDATED                                   | REH 9/18/17                          | 3362 | APPRD. / DATE<br>REH 3/3/16                              |   |
| REV   | DESCRIPTION   | BY / DATE                            | CCN  |  |   |
| ALL DIMENSIONS ARE IN DECIMAL INCHES<br>TOLERANCES UNLESS OTHERWISE SPECIFIED |   | THIRD ANGLE PROJECTION<br>ANSI 14.5M |      | SHOT WEIGHT:   | NOTES:<br>1.) REFERENCE COMPONENT<br>PRINTS FOR DETAILS<br>2.) PATENT 9,162,816 |
| POLYETHYLENE<br>±1% @ 68°F  | METAL<br>DECIMAL ± .125"<br>FRACTION ± 1/4"<br>ANGLE ± 1° |                                      |      | SHIPPING WEIGHT:<br>STANDARD 3202.00 LBS.<br>FINISH: (A) |   |

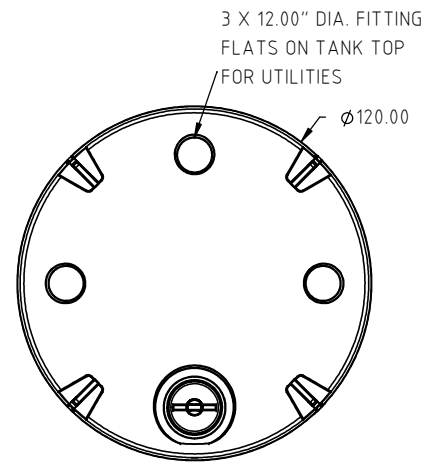
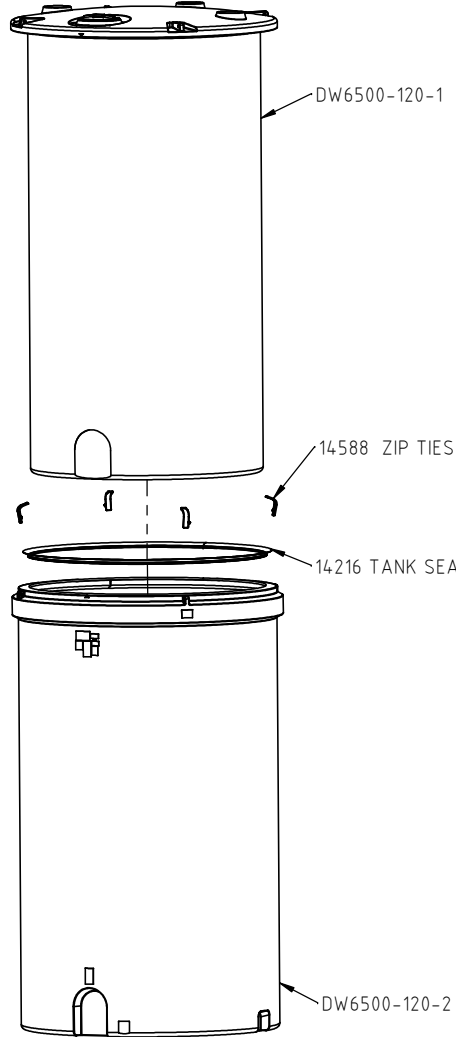

# Den Hartog

INDUSTRIES, INC.

*Acra Roto-Mold Injection Molding Blow Molding Sowjoy*

4010 HOSPERS DRIVE S. BOX 425, HOSPERS, IOWA 51238-0425

|  |                        |
|--|------------------------|
| DESCRIPTION<br><b>6500 GALLON DUAL LINE™ TANK ASSEMBLY</b> |                        |
| SCALE<br>N.S.  | PART NO.<br>DW6500-120 |