

© DEN HARTOG INDUSTRIES, INC.

Copyright. All information furnished within this document, electronic file or design correspondence is the property of Den Hartog industries, Inc. and shall not be used, disclosed to others or copied without the expressed written consent of Den Hartog Industries, Inc.

FM1010-HP 4 PER SET

Ⓔ FM1010-HPS

Ⓕ

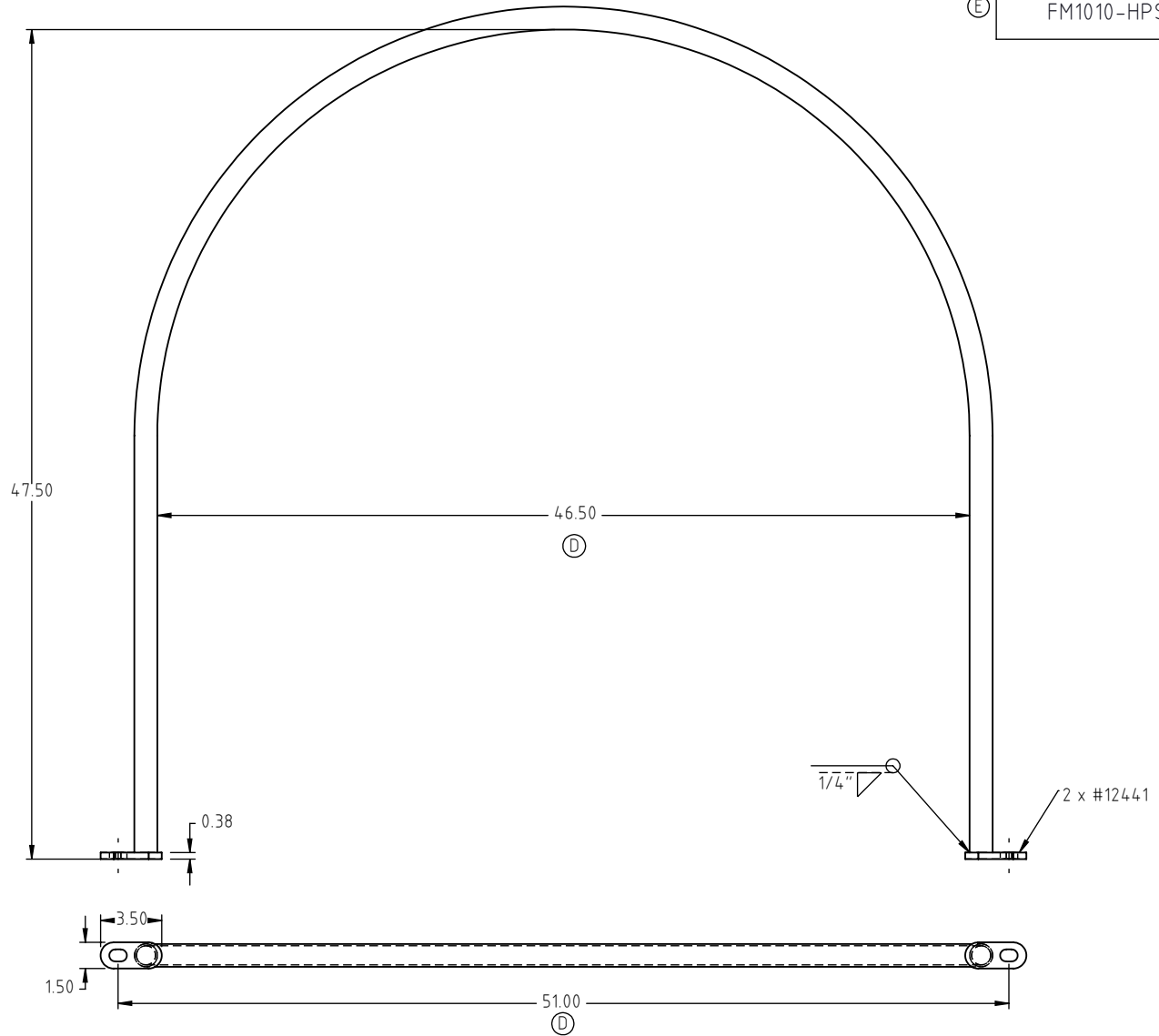

F	CHANGED MATERIAL, UPDATED SHEET FORMAT	SRA	2/7/2024	4559	DRAWN / DATE	MATERIAL :
E	FM1010-HPS WAS FS1010-HPS	ADH	3/4/2015	3026	DHJ 1/29/2003	Ⓕ T1312X01090
D	46.50" WAS 45.00", 51.00" WAS 49.50"	ADH	2/24/2015	3020	APPRD. / DATE	
REV.	DESCRIPTION	BY	DATE	CCN	ADH 11/9/2007	
ALL DIMENSIONS ARE IN DECIMAL INCHES TOLERANCES UNLESS OTHERWISE SPECIFIED		THIRD ANGLE PROJECTION ANSI 14.5M		SHOT WEIGHT:		NOTES: 1. 4 REQUIRED 2. BLANK LENGTH 122.00"
POLYETHYLENE		METAL		SHIPPING WEIGHT: 14.00 LBS		
±1% @ 68°F		DECIMAL ± .125" FRACTION ± 1/4" ANGLE ± 1°		FINISH: Powder Coat		



Den Hartog INDUSTRIES, INC.

Ace Roto-Mold • Injection Molding • Blow Molding • Sowjoy
4010 HOSPERS DRIVE S. BOX 425, HOSPERS, IOWA 51238-0425

DESCRIPTION HOOP FOR 1010 GALLON LEG TANK		SHEET 1 OF 1	
SCALE N.S.	PART NO. Ⓔ FM1010-HPS		