

© DEN HARTOG INDUSTRIES, INC.

Copyright. All information furnished within this document, electronic file or design correspondence is the property of Den Hartog Industries, Inc. and shall not be used, disclosed to others or copied without the expressed written consent of Den Hartog Industries, Inc.

ITEM NO.	PART NUMBER	DESCRIPTION	QTY.
1	FM1310-SKCO	1310 GALLON LEG TANK-CENTER SUMP	1
2	FS19419	RETAINING PLATE	4
3	SJ10937	WASHER, 3/8" FLAT ZINC	16
4	11092	BOLT, 3/8" X 1-1/5" GR 5 ZINC	8
5	11093	NUT, 3/8" HEX GR 2 ZINC	8

FM1310-SKC

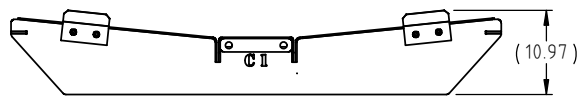
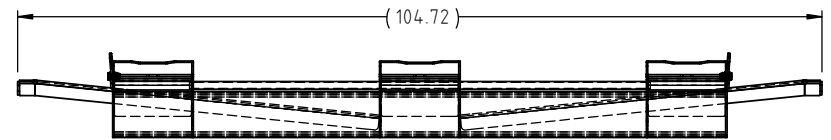
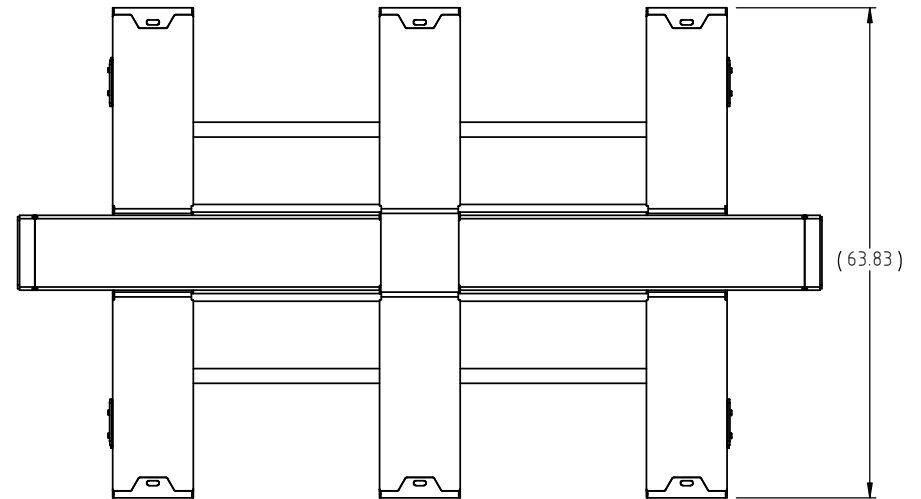
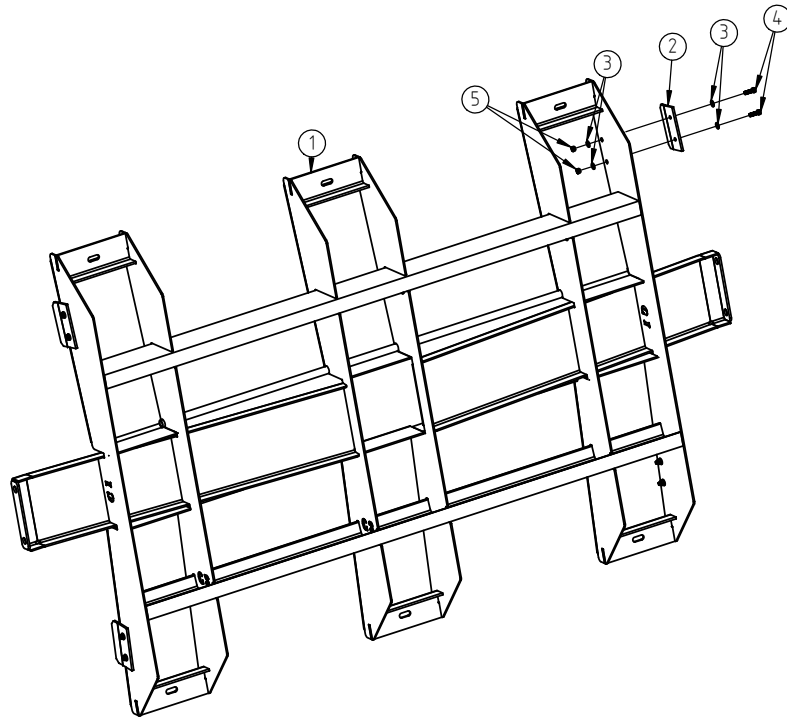
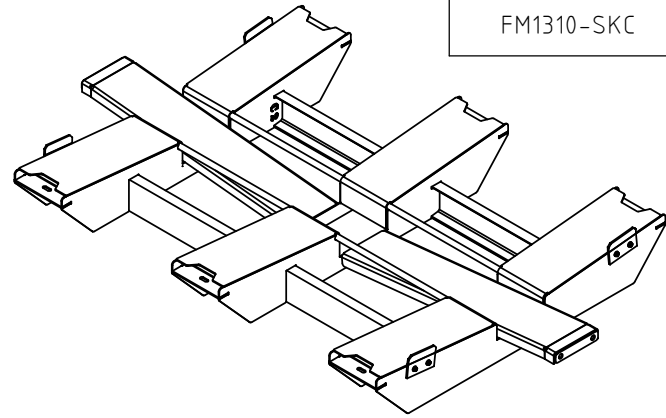

				DRAWN / DATE ADH 10/1/20 APPRD. / DATE BPL 10/1/20	MATERIAL SEE COMPONENTS
REV	DESCRIPTION	BY / DATE	CCN	SHOT WEIGHT: SHIPPING WEIGHT: 415.00 LBS FINISH:	
ALL DIMENSIONS ARE IN DECIMAL INCHES TOLERANCES UNLESS OTHERWISE SPECIFIED POLYETHYLENE		THIRD ANGLE PROJECTION ANSI 14.5M		NOTES:	
METAL DECIMAL ± .125" FRACTION ± 1/4" ANGLE ± 1°				SCALE N.S.	
±1% @ 68°F				PART NO. FM1310-SKC	



Den Hartog
INDUSTRIES, INC.

Ace Roto-Mold Injection Molding Blow Molding Sowjoy

4010 HOSPERS DRIVE S. BOX 425, HOSPERS, IOWA 51238-0425

DESCRIPTION 1310 GALLON LEG TANK SKID-CENTER SUMP

SCALE N.S.

PART NO. FM1310-SKC

SHEET 1 OF 1