

Copyright. All information furnished within this document, electronic file or design correspondence is the property of Den Hartog Industries, Inc. and shall not be used, disclosed to others or copied without the expressed written consent of Den Hartog Industries, Inc.

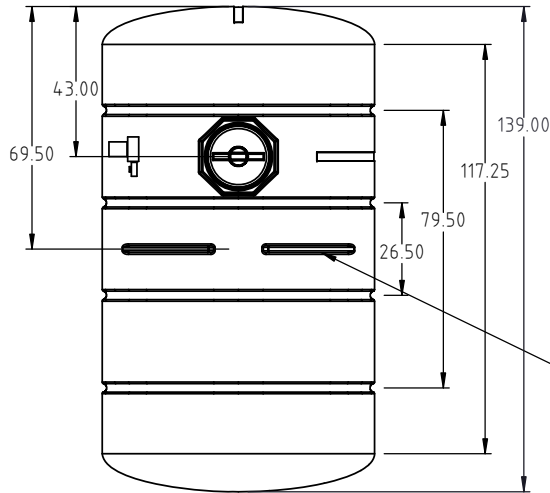

FM1610-78C
CENTER DRAIN SUMP

BAFFLE KEYS 4 PLACES
INSTALL BAFFLES AND STRUTS FOR SHIPMENT. SEE FS1610-78 BAFFLE ASSEMBLY DIAGRAM

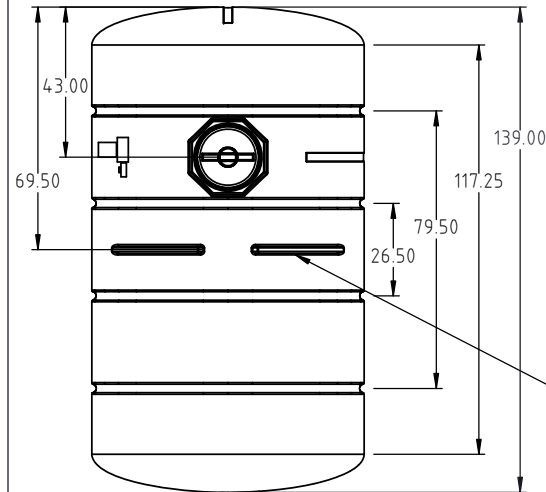

FM1610-78E
END DRAIN SUMP

BAFFLE KEYS 4 PLACES
INSTALL BAFFLES AND STRUTS FOR SHIPMENT. SEE FS1610-78 BAFFLE ASSEMBLY DIAGRAM.

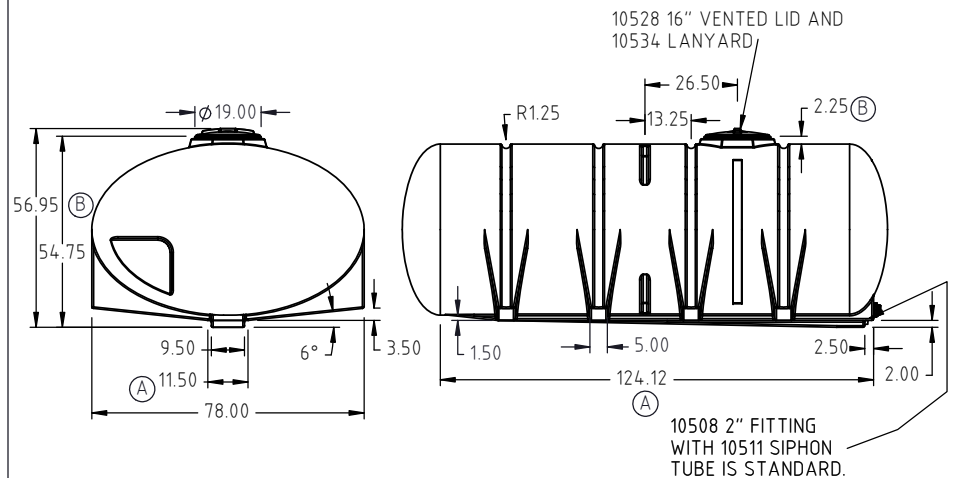
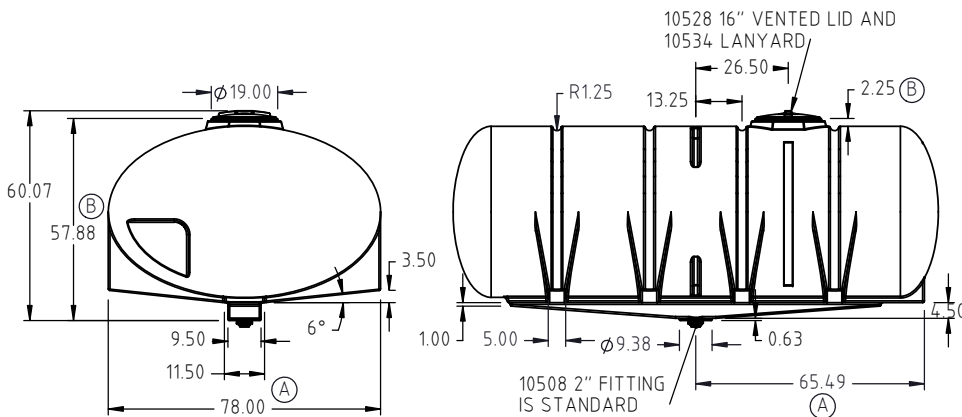

B	2.25" WAS 4.00". 57.88" WAS 60.00". 54.75" WAS 57.50". DRAWING TEMPLATE.	ADH	5/26/2023	4429
A	FITTING FLAT DETAILS ADDED.	ADH	1/10/2013	2561
REV.	DESCRIPTION	BY	DATE	CCN
ALL DIMENSIONS ARE IN DECIMAL INCHES TOLERANCES UNLESS OTHERWISE SPECIFIED		THIRD ANGLE PROJECTION ANSI 14.5M		
POLYETHYLENE	METAL DECIMAL ± .125" FRACTION ± 1/4" ANGLE ± 1°			
±1% @ 68°F				

DRAWN / DATE	MATERIAL :
ADH 7/1/2010	10538
APPRD. / DATE	
REH 7/1/2010	
SHOT WEIGHT: 490.00 LBS.	NOTES:
SHIPPING WEIGHT: 530.00 LBS. (INC. BAFFLE)	1.) WHITE OR YELLOW COLOR
FINISH:	NOMINAL WALL THICKNESS: 0.375"



Den Hartog INDUSTRIES, INC.

Ace Roto-Mold • Injection Molding • Blow Molding • Sowjoy
4010 HOSPERS DRIVE S. BOX 425, HOSPERS, IOWA 51238-0425

DESCRIPTION 1610 GALLON LEG TANK		
SCALE N.S.	PART NO. FM1610-78	SHEET 1 OF 1