

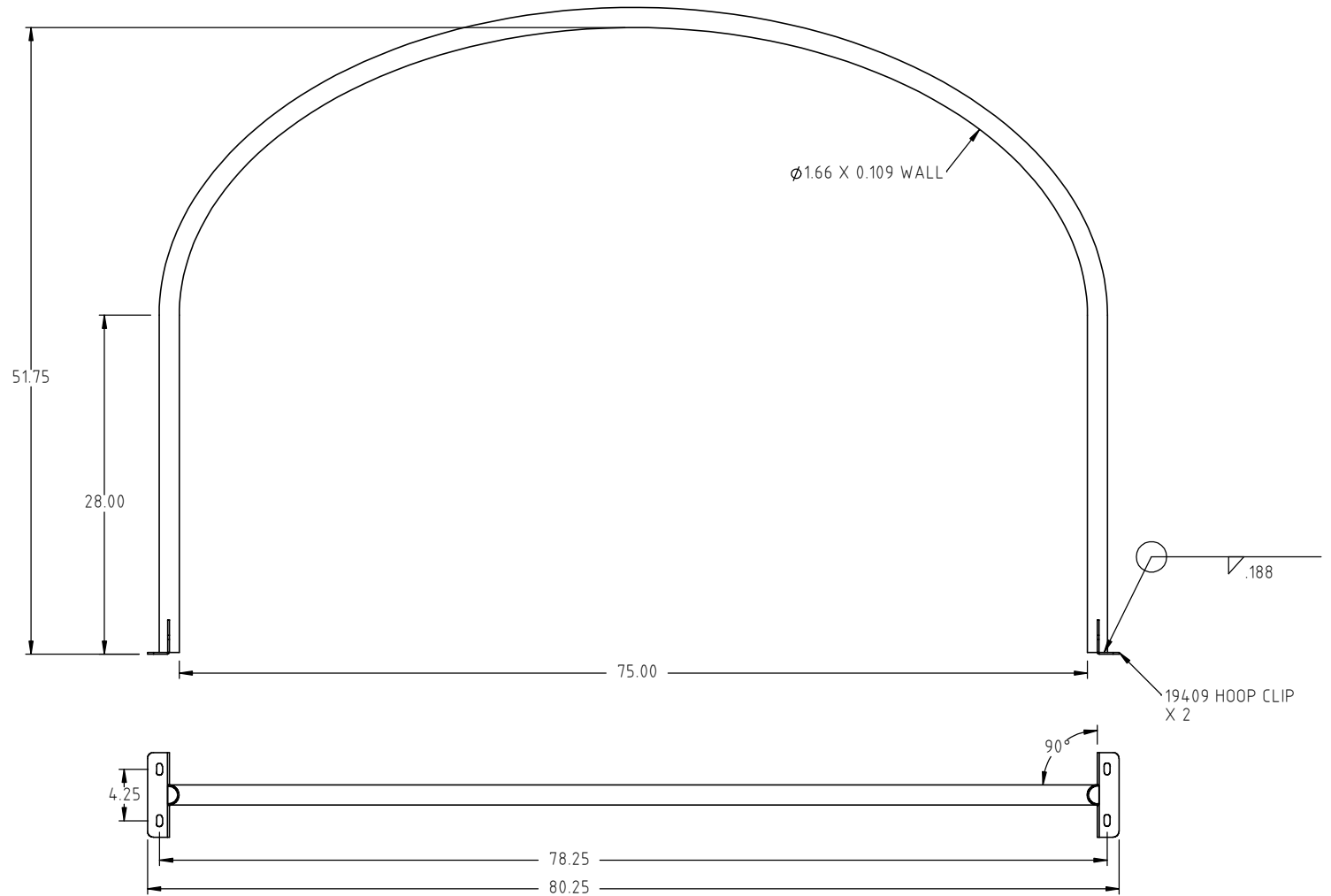

© DEN HARTOG INDUSTRIES, INC.

FM1850-HPFS

Copyright. All information furnished within this document, electronic file or design correspondence is the property of Den Hartog industries, Inc. and shall not be used, disclosed to others or copied without the expressed written consent of Den Hartog Industries, Inc.

FM1850-HP 4 PER SET

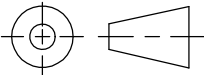

				DRAWN / DATE DHJ 1/12/12	MATERIAL MILD STEEL	 <p>Den Hartog INDUSTRIES, INC. Ace Roto-Mold Injection Molding Blow Molding Sowjoy 4010 HOSPERS DRIVE S. BOX 425, HOSPERS, IOWA 51238-0425</p>
				APPRD. / DATE REH 2/21/12		
REV	DESCRIPTION	BY / DATE	CCN			DESCRIPTION FM 1850 HOOP WELDMENT
ALL DIMENSIONS ARE IN DECIMAL INCHES TOLERANCES UNLESS OTHERWISE SPECIFIED POLYETHYLENE ±1% @ 68°F		THIRD ANGLE PROJECTION ANSI 14.5M 		SHOT WEIGHT:	NOTES: 1.) BLANK LENGTH: 155"	SCALE N.S.
				SHIPPING WEIGHT: 30.00 LBS		FINISH: BLACK POWDER COAT