

Copyright. All information furnished within this document, electronic file or design correspondence is the property of Den Hartog industries, Inc. and shall not be used, disclosed to others or copied without the expressed written consent of Den Hartog Industries, Inc.

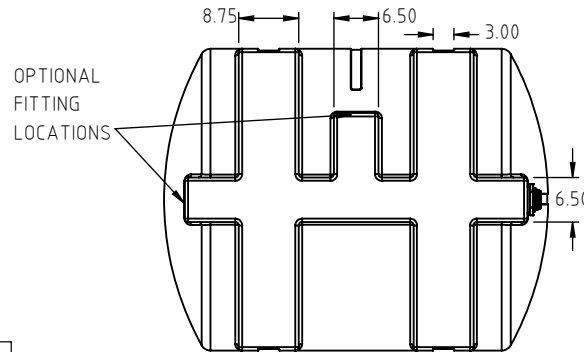

D	CORRECTED FITTING SIZE OPTIONS	NHW	4/21/2021	4115
C	LABEL DETAIL ADDED TO THE PRINT	ADH	12/20/17	3481
B	CLARIFY STANDARD FITTING	DHJ	10/2/07	
A	NEW DRAWING FORMAT	NVE	10/11/05	
REV.	DESCRIPTION	BY	DATE	CCN

DRAWN / DATE	MATERIAL
DHJ 12/20/02	HDPE OR EQUIVALENT REFERENCE MATERIAL DATA SHEET FOR SPECIFIC PROPERTIES.
APPROD. / DATE	
ADH 11/9/07	

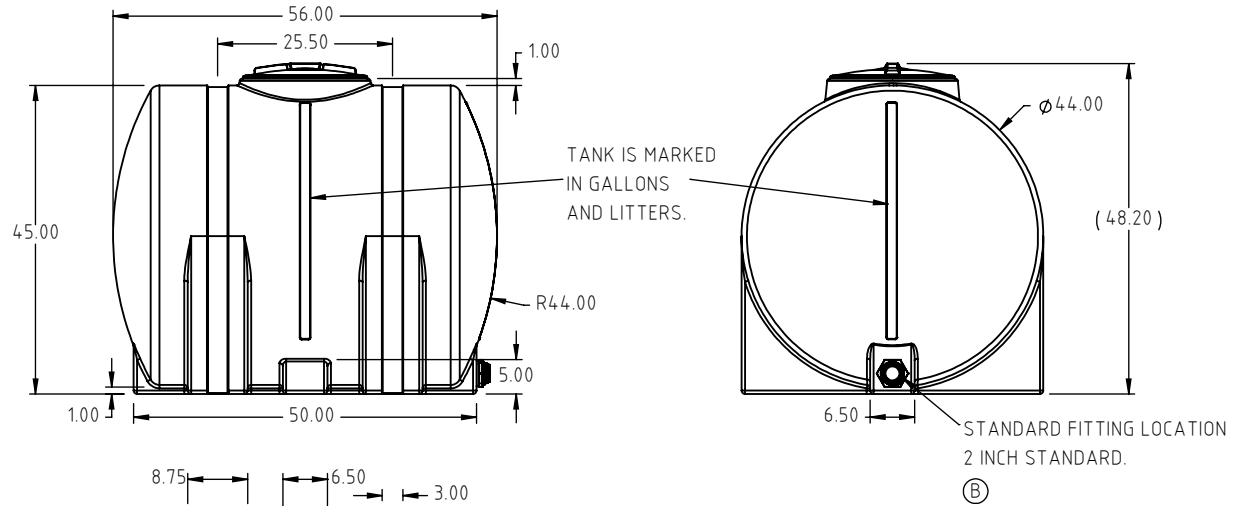
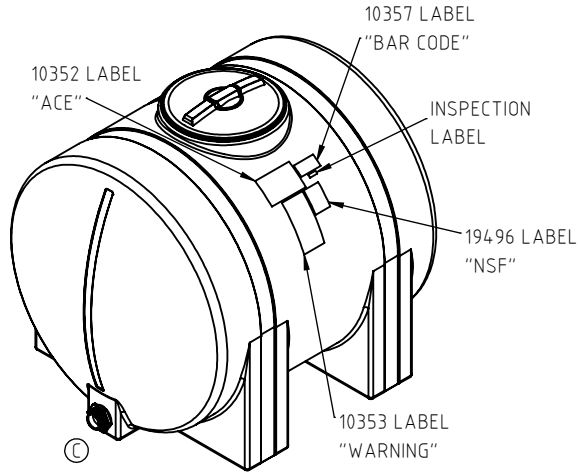
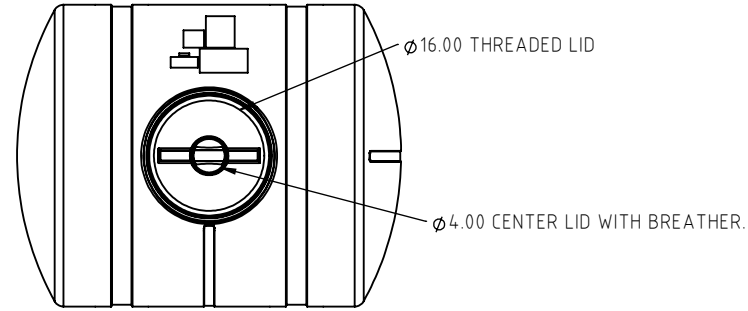

Den Hartog
INDUSTRIES, INC.

Ace Roto-Mold Injection Molding Blow Molding Sowjoy

4010 HOSPERS DRIVE S. BOX 425, HOSPERS, IOWA 51238-0425

ALL DIMENSIONS ARE IN DECIMAL INCHES
TOLERANCES UNLESS OTHERWISE SPECIFIED

POLYETHYLENE
±1% @ 68°F

THIRD ANGLE PROJECTION
ANSI 14.5M

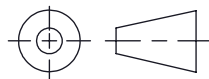

SHOT WEIGHT:	116.00 LBS
SHIPPING WEIGHT:	118.00 LBS
FINISH:	

NOTES:
1.) WHITE, BLACK, YELLOW
OR DESSERT TAN.
2.) NOM. WALL @ 0.290".
3.) 3/4", 1", 1.25", 1.5", 2" OR
3" FITTING.

DESCRIPTION	335 GALLON FREE-STANDING TANK	
SCALE	N.S.	PART NO. FS0335-44