

PROPRIETARY DATA

PROPERTY OF DEN HARTOG INDUSTRIES, INC. INFORMATION FURNISHED HEREIN IS THE PROPERTY OF DEN HARTOG INDUSTRIES, INC. AND SHALL NOT BE USED, DISCLOSED TO OTHERS, OR COPIED WITHOUT THE EXPRESSED WRITTEN CONSENT OF DEN HARTOG INDUSTRIES, INC. ALL RIGHTS RESERVED.

FS0335-SBPJ 2 PER KIT

MATERIAL/PART SCHEDULE

FS0335-SBPJS

C

PART#	DESCRIPTION	QTY.
S-14GA	14GA MILD STEEL SHEET	330 SI
SJ10937	3/8" FLAT WASHER	2

©

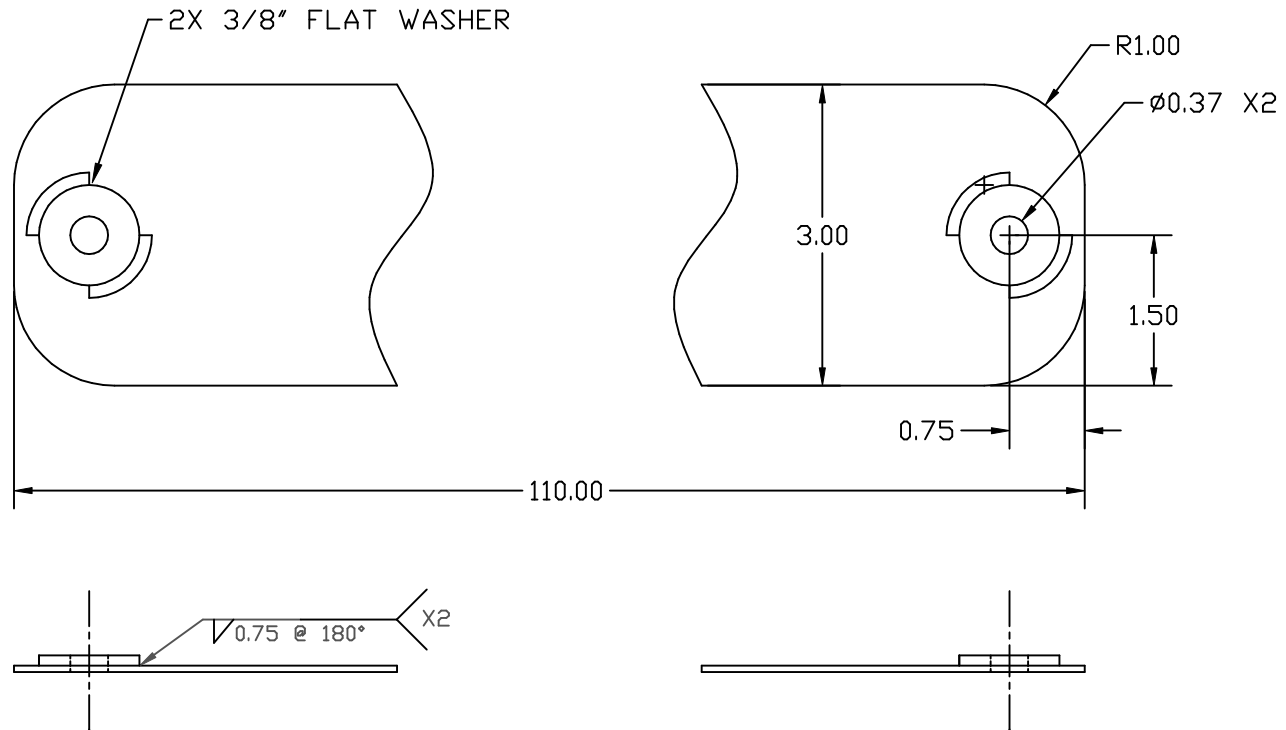

REV	DESCRIPTION	DATE	APPRD	DRAWN / DATE	MATERIAL
C	ADD TEXT BOX	3/30/07	GWC	DRAWN / DATE NVE 12/7/05	14GA (.0747) MILD STEEL
B	TOLERANCE WAS 1% @ 68° F	3/16/07	GWC		
A	UPDATED PRINT, ADDED WELD DESC.	6/21/06	NVE	APPRD. / DATE REH/11/13/06	

ACE ROTO-MOLD
 A DIVISION OF DEN HARTOG INDUSTRIES, INC.
 4018 HWY. 60 BLVD., BOX 421, HOSPERS, IOWA 51238

CLIENT / DESCRIPTION
 STEEL BAND (FOR J-BOLT) FOR 335 GALLON LEG TANK

ALL DIMENSIONS ARE IN DECIMAL INCHES
 TOLERANCES UNLESS OTHERWISE SPECIFIED
 DECIMAL +/- .064"
 FRACTION +/- 1/8"
 ANGLE +/- 1°

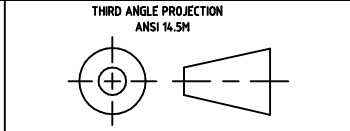

NOTES:
 1. POWDER COATED
 2. WEIGHT 7.00 LBS.

SCALE N.S.	PART NO. FS0335-SBPJS
---------------	--------------------------