

PROPRIETARY DATA

PROPERTY OF DEN HARTOG INDUSTRIES, INC. INFORMATION FURNISHED HEREIN IS THE PROPERTY OF DEN HARTOG INDUSTRIES, INC. AND SHALL NOT BE USED, DISCLOSED TO OTHERS, OR COPIED WITHOUT THE EXPRESSED WRITTEN CONSENT OF DEN HARTOG INDUSTRIES, INC. ALL RIGHTS RESERVED.

FS125/165-SBPFS

B

FS125/165-SBPF 2 PER SET

ⓑ

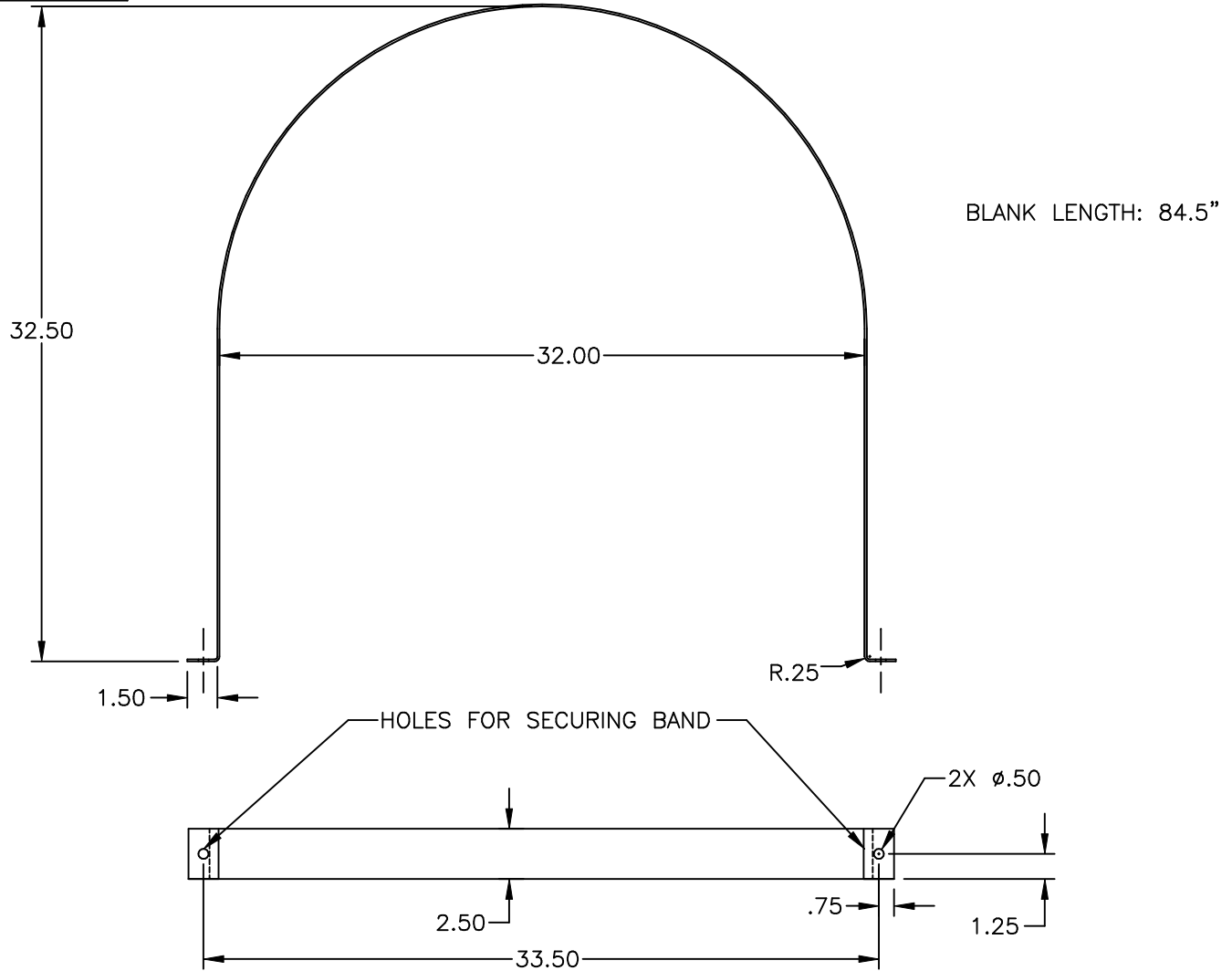

				DRAWN / DATE NVE 6/29/05	MATERIAL 10 GA (.1345) G90 STEEL
B	ADD TEXT BOX / FIX DESCRIPTION	4/2/07	GWC	APPRD. / DATE DHJ 9/27/05	
A	TOLERANCE WAS 1% @ 68° F	3/16/07	GWC		
REV	DESCRIPTION	DATE	APPRD		
ALL DIMENSIONS ARE IN DECIMAL INCHES TOLERANCES UNLESS OTHERWISE SPECIFIED DECIMAL +/- .125" FRACTION +/- 1/4" ANGLE +/- 2°				THIRD ANGLE PROJECTION ANSI 14.5M 	NOTES: 1. POWDER COATED SILVER 2. WEIGHT 8 LBS.



ACE ROTO-MOLD
 A DIVISION OF DEN HARTOG INDUSTRIES, INC.
 4018 HWY. 60 BLVD., BOX 421, HOSPERS, IOWA 51238

CLIENT / DESCRIPTION	
125/165 GALLON SILVER POWDER-COATED FORMED STEEL BAND W/ FEET	
SCALE	PART NO.
N.S.	FS125/165-SBPFS