

Copyright. All information furnished within this document, electronic file or design correspondence is the property of Den Hartog Industries, Inc. and shall not be used, disclosed to others or copied without the expressed written consent of Den Hartog Industries, Inc.

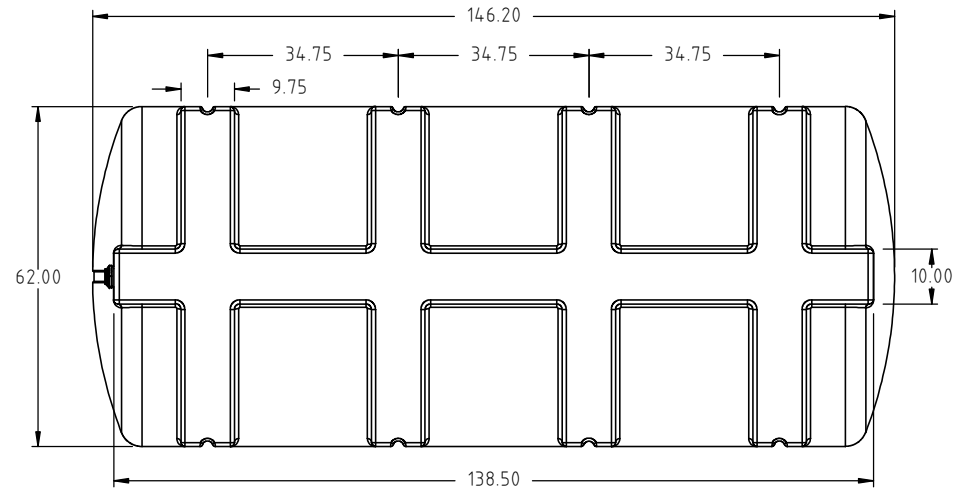

NOTE: 4 HOOPS ARE REQUIRED ON THIS TANK
NOTE: FS1750-BAF KIT IS STANDARD

C	BAFFLE ENGAGEMENT POINTS ADDED.	ADH 4/17/17	3378	DRAWN / DATE	MATERIAL HDPE
B	BAFFLE FEATURES REMOVED. DRAWING TEMPLATE UPDATED.	ADH 6/30/16	3260	DHJ 09/10/07	
A	BAFFLE KIT MADE STANDARD	ADH 5/15/08		APPRD. / DATE	
REV	DESCRIPTION	BY / DATE	CCN	REH 10/1/07	
ALL DIMENSIONS ARE IN DECIMAL INCHES TOLERANCES UNLESS OTHERWISE SPECIFIED		THIRD ANGLE PROJECTION ANS1 14.5M		SHOT WEIGHT: 540.00 LBS	NOTES: 1.) AVAILABLE IN NATURAL OR YELLOW COLOR 2.) NOM. WALL = 0.400
POLYETHYLENE ±1% @ 68°F		METAL DECIMAL ± .125" FRACTION ± 1/4" ANGLE ± 1°		SHIPPING WEIGHT:	
				FINISH:	

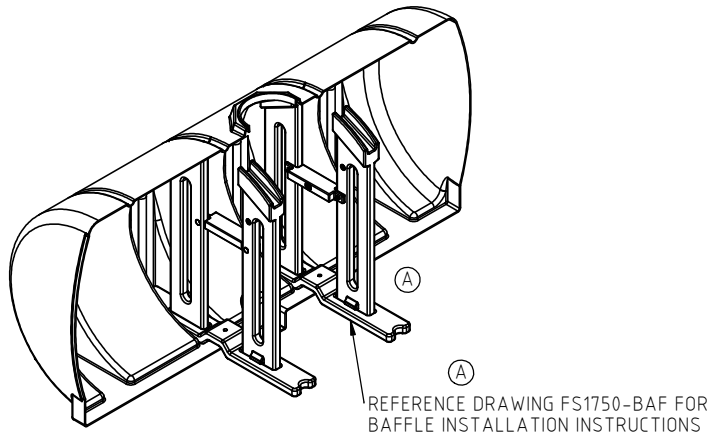
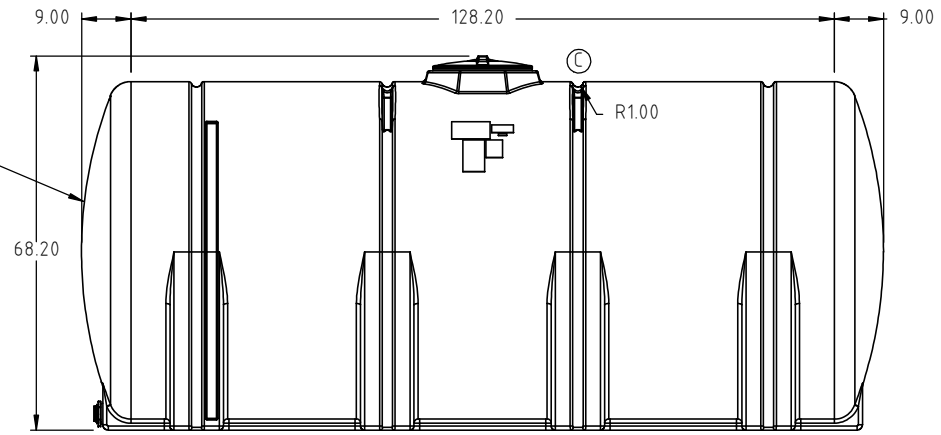
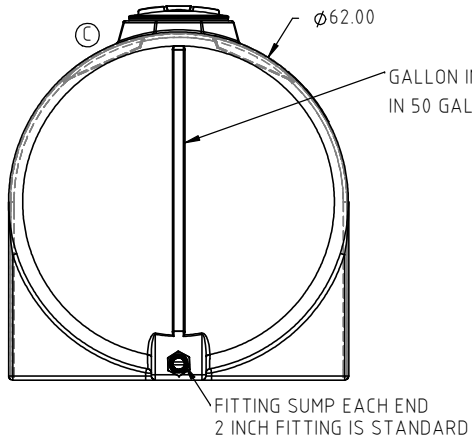

Den Hartog
INDUSTRIES, INC.

Ace Roto-Mold Injection Molding Blow Molding Sowjoy

4010 HOSPERS DRIVE S. BOX 425, HOSPERS, IOWA 51238-0425

DESCRIPTION	1750 GAL. LEG TANK	
SCALE	N.S.	PART NO. FS1750-62

Copyright. All information furnished within this document, electronic file or design correspondence is the property of Den Hartog Industries, Inc. and shall not be used, disclosed to others or copied without the expressed written consent of Den Hartog Industries, Inc.



COMPONENT	PART NUMBER	DESCRIPTION	QTY.
1	12469	BOLT, 3/8"-16 X 3-1/2" SS	4
2	11094	WASHER, 3/8" X 1" OD FLAT SS	8
3	10223	NUT, 3/8" STAINLESS NYLOK	4
4	12480	BAFFLE TIE	2
5	12481	BAFFLE	4
6	12482-BM	BAFFLE STRUT	2

(A) (C)

Installation Instructions

1. Insert Baffles, Tie and Strut through lid opening.
2. It will be necessary to enter tank for assembly.
CAUTION: NEVER ENTER A TANK EXPOSED TO CHEMICALS WITHOUT THE PROPER SAFETY EQUIPMENT.
3. Place Bottom Tie into middle leg bays.
4. Engage Baffles into Tie slots.
5. Position Strut between Baffles.
6. Fasten Strut to Baffles with hardware as shown.
7. IMPORTANT: 4 Hoops must be installed on this tank.
8. Periodically check and retighten all hoops as necessary.

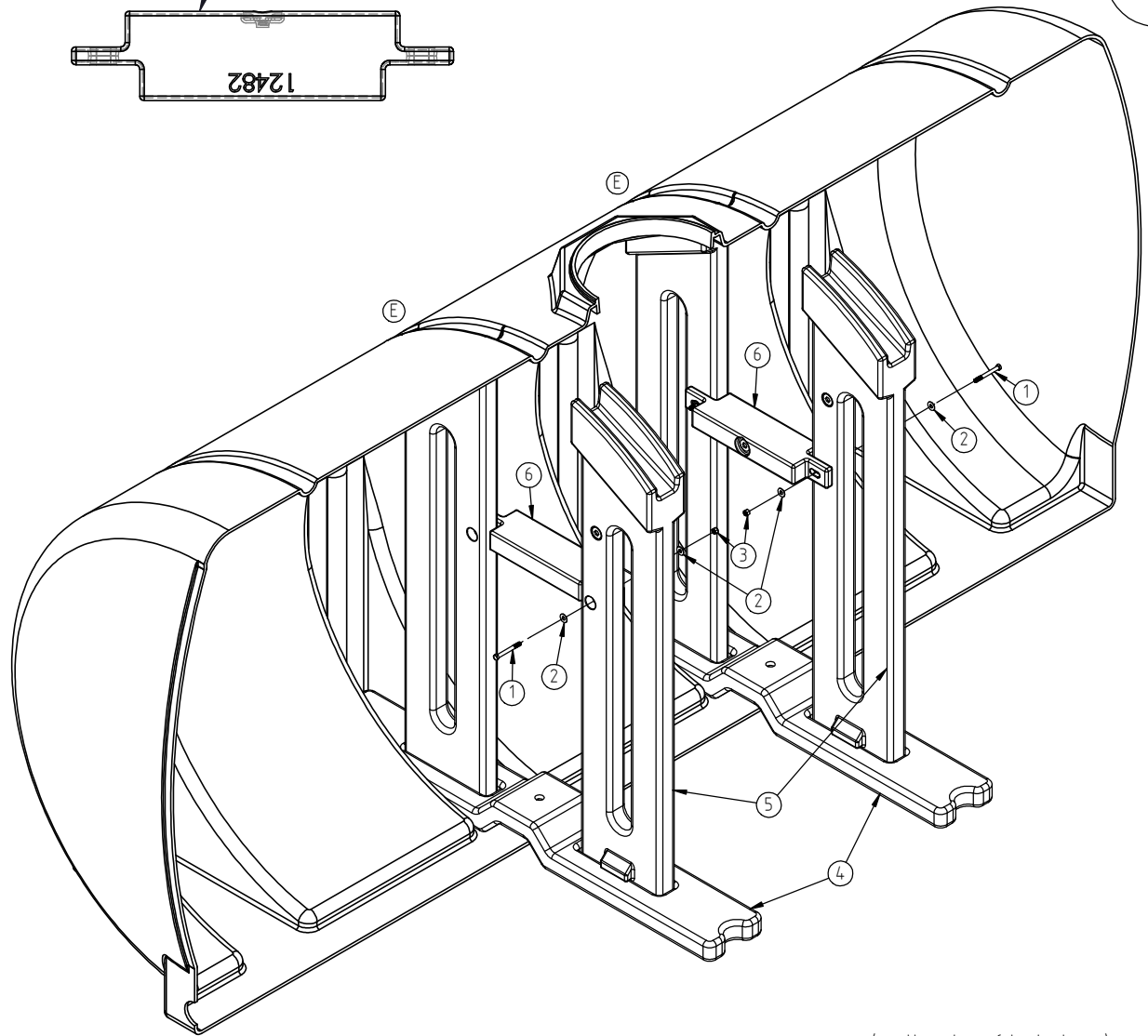

(section view of tank shown)

E	BAFFLE ENGAGEMENT POINTS ADDED TO TANK	ADH 4/17/17	3378
D	BAFFLE FEATURES REMOVED. TEMPLATE UPDATED.	ADH 6/30/16	3260
C	12469 WAS 12511	REH 7/23/09	1901
B	CLARIFY STRUT INSTALLATION	REH 1/20/09	1788
A	12511 WAS 12469	REH 11/19/07	1511
REV	DESCRIPTION	BY / DATE	CCN

DRAWN / DATE	MATERIAL
ADH 9/6/07	
APPROD. / DATE	
REH/9/17/07	



Den Hartog
INDUSTRIES, INC.

Ace Roto-Mold Injection Molding Blow Molding Sowjoy

4010 HOSPERS DRIVE S. BOX 425, HOSPERS, IOWA 51238-0425

ALL DIMENSIONS ARE IN DECIMAL INCHES TOLERANCES UNLESS OTHERWISE SPECIFIED	
POLYETHYLENE	METAL
±1% @ 68°F	DECIMAL ± .125" FRACTION ± 1/4" ANGLE ± 1°

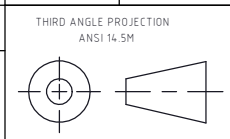

SHOT WEIGHT:	NOTES:
SHIPPING WEIGHT:	
FINISH:	

DESCRIPTION	1750 BAFFLE KIT INSTALLATION INSTRUCTIONS	
SCALE	N.S.	PART NO. FS1750-BAF

Copyright. All information furnished within this document, electronic file or design correspondence is the property of Den Hartog Industries, Inc. and shall not be used, disclosed to others or copied without the expressed written consent of Den Hartog Industries, Inc.

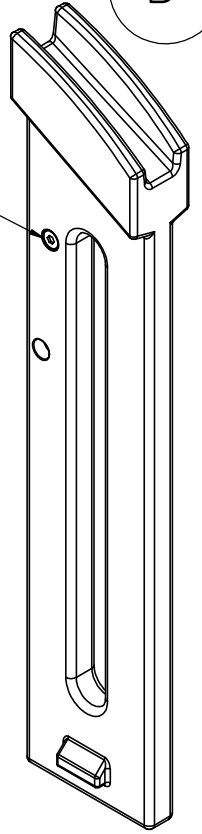
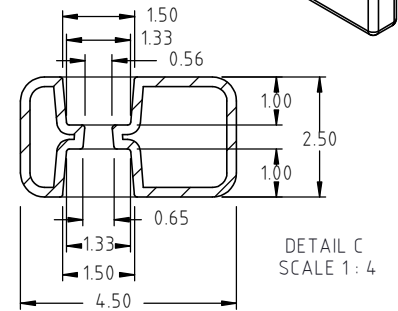
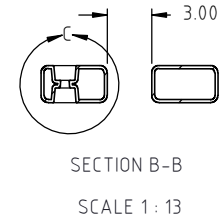
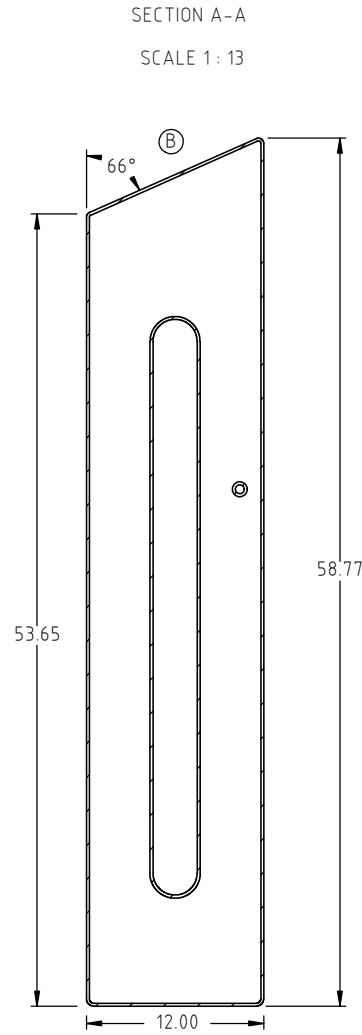
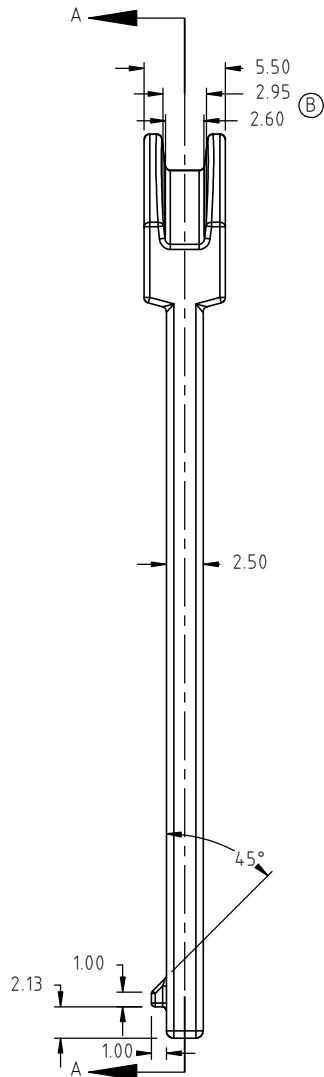
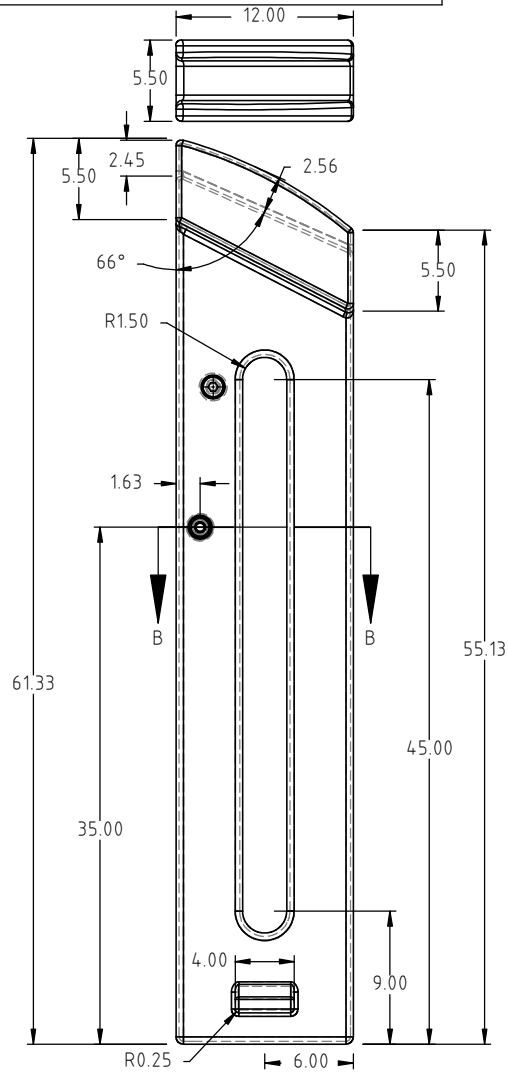

				DRAWN / DATE ADH 9/7/07	MATERIAL (A) 11017 3 MELT BLACK REGRIND IS PRIMARY MATERIAL. 13472, 2 MELT BLACK REGRIND MAY BE SUBSTITUTED
B	DESIGN OF BAFFLE TOP UPDATED. ENGAGEMENT MADE FLATTER AND DEEPER.	ADH 4/17/17	3378	APPRD. / DATE REH 9/17/07	
A	MATERIAL NOTE, DRAWING TEMPLATE UPDATED.	10/10/13	2712		
REV	DESCRIPTION	BY / DATE	CCN		
ALL DIMENSIONS ARE IN DECIMAL INCHES TOLERANCES UNLESS OTHERWISE SPECIFIED		THIRD ANGLE PROJECTION ANSI 14.5M		SHOT WEIGHT: 12.00 LBS	NOTES: 1.) NOM. WALL @ .250 2.) BLACK COLOR
POLYETHYLENE		METAL DECIMAL ± .125" FRACTION ± 1/4" ANGLE ± 1°		SHIPPING WEIGHT:	
±1% @ 68°F				FINISH:	



Den Hartog
INDUSTRIES, INC.

Ace Roto-Mold Injection Molding Blow Molding Sowjoy

4010 HOSPERS DRIVE S. BOX 425, HOSPERS, IOWA 51238-0425

DESCRIPTION BAFFLE FOR 1750 GALLON FREE-STANDING LEG TANK

SCALE N.S.

PART NO. 12481