

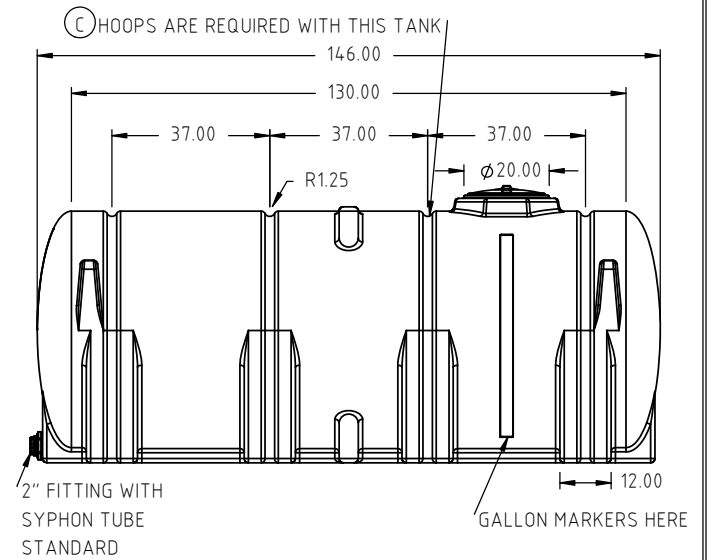

Copyright. All information furnished within this document, electronic file or design correspondence is the property of Den Hartog Industries, Inc. and shall not be used, disclosed to others or copied without the expressed written consent of Den Hartog Industries, Inc.

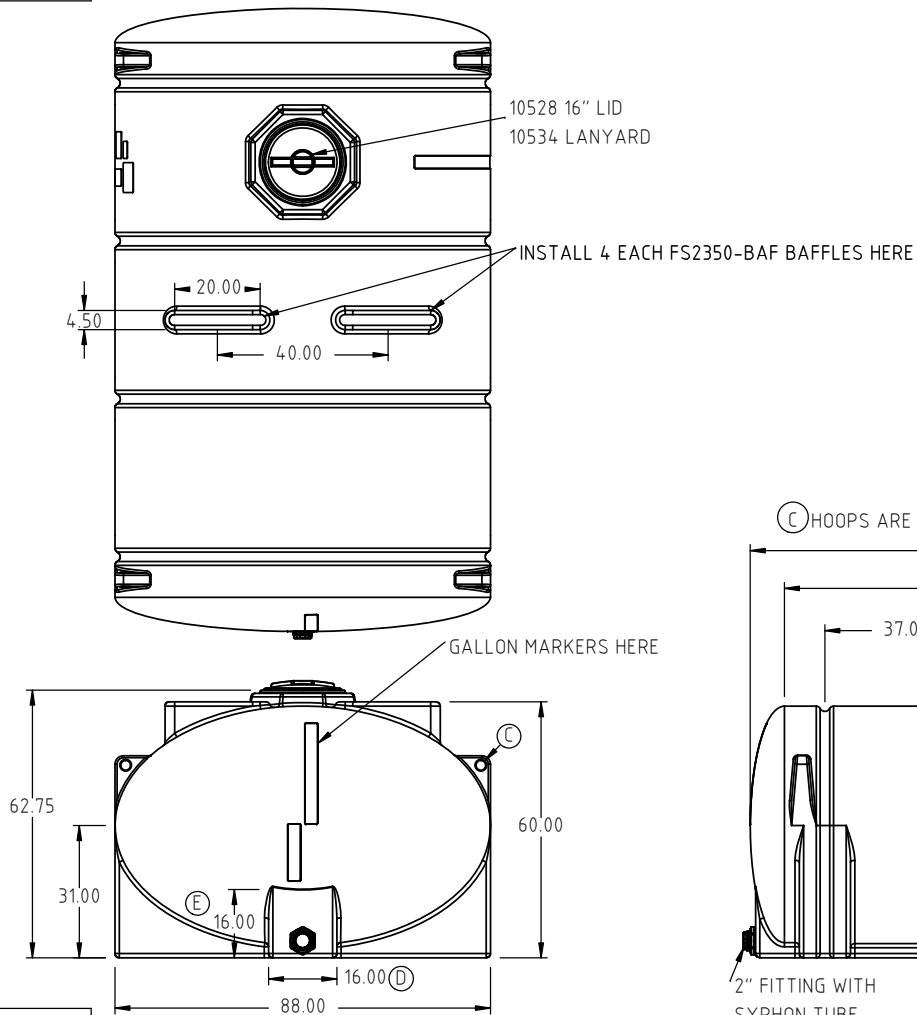

E	16.00" CORRECTED FROM 9.42"	ADH 9/6/19	3839
D	16.00" WAS 12.00"	ADH 1/27/12	2358
C	SHIP WT., NOTES ADDED, LIFTING LUGS SHOWN	ADH 4/7/10	2015
B	TOLERANCE AND ADDRESS UPDATED	ADH 2/16/09	1800
A	CHANGED PART #	4/6/06	
REV	DESCRIPTION	BY / DATE	CCN

DRAWN / DATE	MATERIAL
DHJ 9/22/04	10538 NATURAL
APPRD. / DATE	
REH 9/22/04	



Den Hartog
INDUSTRIES, INC.

Ace Roto-Mold Injection Molding Blow Molding Sowjoy

4010 HOSPERS DRIVE S. BOX 425, HOSPERS, IOWA 51238-0425

ALL DIMENSIONS ARE IN DECIMAL INCHES
TOLERANCES UNLESS OTHERWISE SPECIFIED

POLYETHYLENE
±1% @ 68°F

METAL
DECIMAL ± .125"
FRACTION ± 1/4"
ANGLE ± 1°

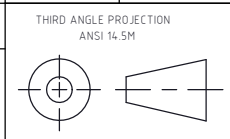

SHOT WEIGHT:	840 LBS.
SHIPPING WEIGHT:	920 LBS.
FINISH:	

NOTES:
1.) 0.480 NOMINAL WALL
2.) BLUE, BLACK, WHITE
OR YELLOW COLOR

DESCRIPTION	2350 GALLON ELLIPTICAL LEG TANK	
SCALE	N.S.	PART NO. FS2350-88