

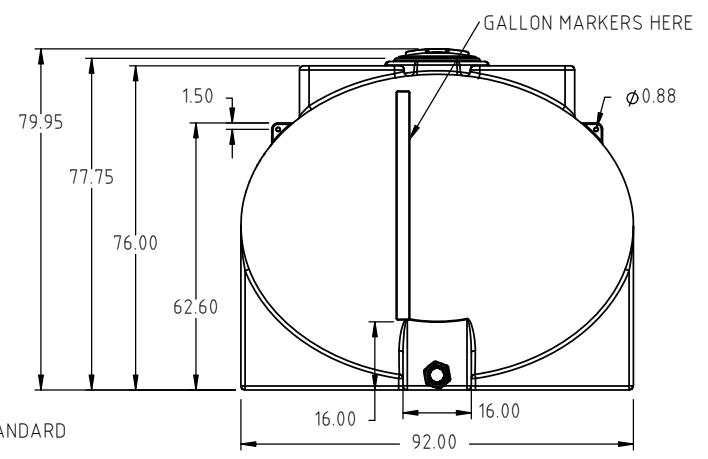

Copyright. All information furnished within this document, electronic file or design correspondence is the property of Den Hartog Industries, Inc. and shall not be used, disclosed to others or copied without the expressed written consent of Den Hartog Industries, Inc.

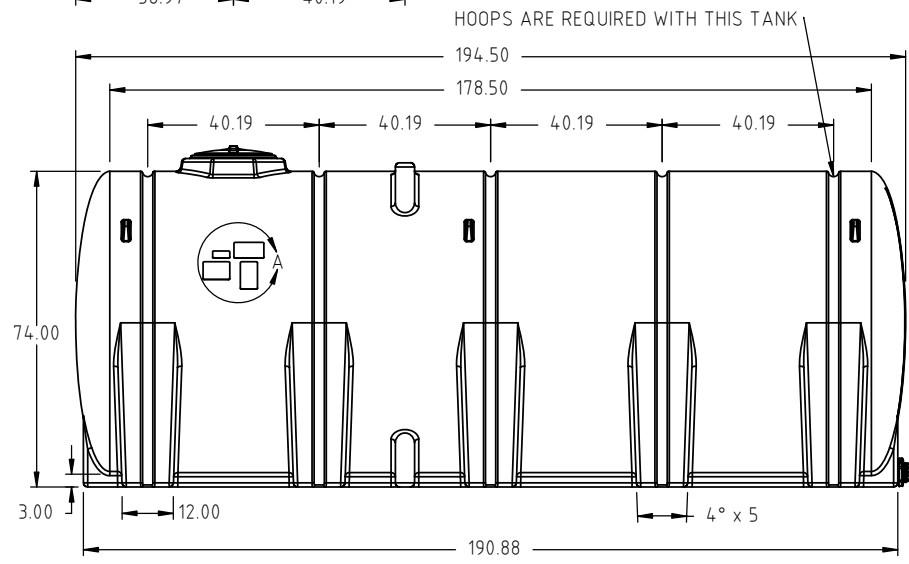

REV		DESCRIPTION	BY / DATE	CCN	DRAWN / DATE ADH 3/13/17	MATERIAL 12532 BLACK RESIN 10538 NATURAL
					APPRD. / DATE REH 6/9/15	
					SHOT WEIGHT: 1541 LBS.	NOTES: 1.) .590 NOMINAL WALL
					SHIPPING WEIGHT: 1648 LBS.	
					FINISH:	
ALL DIMENSIONS ARE IN DECIMAL INCHES TOLERANCES UNLESS OTHERWISE SPECIFIED		THIRD ANGLE PROJECTION ANSI 14.5M				
POLYETHYLENE ±1% @ 68°F		METAL DECIMAL ± .125" FRACTION ± 1/4" ANGLE ± 1°				

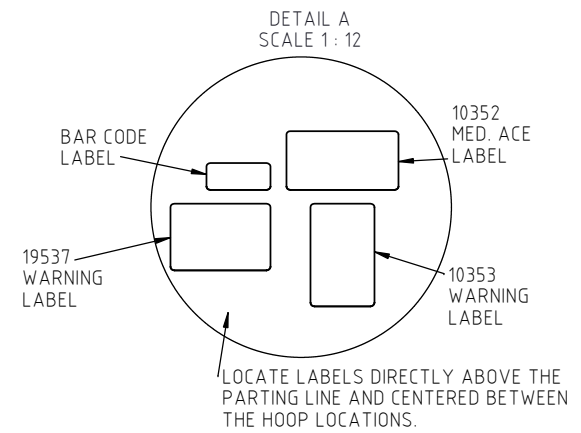
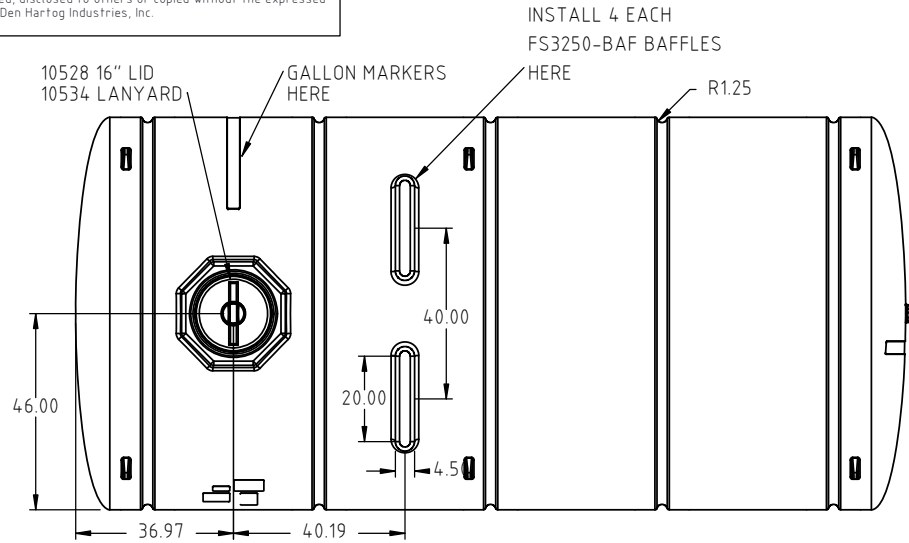

Den Hartog
INDUSTRIES, INC.

Ace Roto-Mold Injection Molding Blow Molding Sowjoy

4010 HOSPERS DRIVE S. BOX 425, HOSPERS, IOWA 51238-0425

DESCRIPTION 4200 GALLON ELLIPTICAL LEG TANK	
SCALE N.S.	PART NO. FS4200-92