

Copyright. All information furnished within this document, electronic file or design correspondence is the property of Den Hartog industries, Inc. and shall not be used, disclosed to others or copied without the expressed written consent of Den Hartog Industries, Inc.

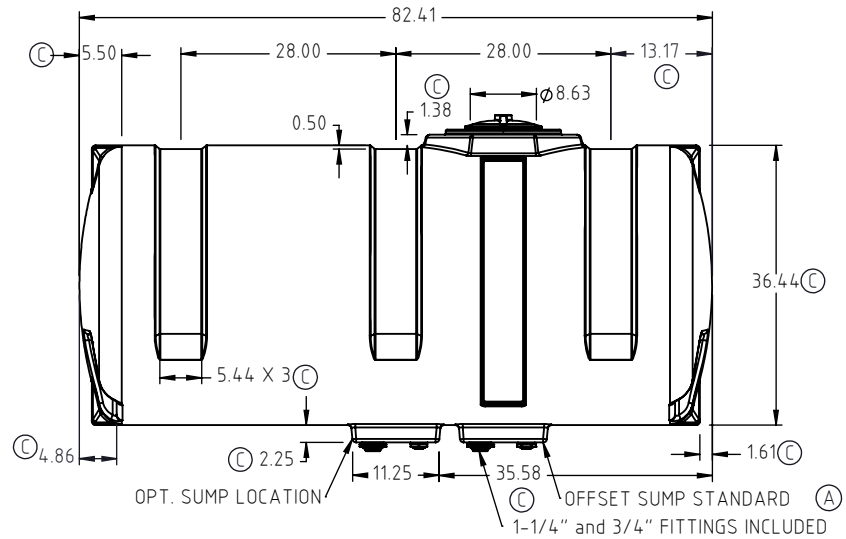

B

C	DIMENSIONS UPDATED, LABELS ADDED TO PRINT.	ADH	9/6/2023	4572	DRAWN / DATE	MATERIAL :
B	57.00 WAS SHOWN AS 69.00, NOTES REMOVED. 7.00 WAS 7.50, 10.50 WAS 12.50.	ADH	2/12/2015	3012	REH 4/16/2001	LLDPE
A	CLARIFY STANDARD SUMP.	DHJ	5/7/2013	2617	APPRD. / DATE	
REV.	DESCRIPTION	BY	DATE	CCN	DHJ 4/16/2001	
ALL DIMENSIONS ARE IN DECIMAL INCHES TOLERANCES UNLESS OTHERWISE SPECIFIED		THIRD ANGLE PROJECTION ANSI 14.5M		SHOT WEIGHT: 163.00 LBS		NOTES: NOMINAL WALL THICKNESS: 0.310"
POLYETHYLENE		METAL		SHIPPING WEIGHT: 165.00 LBS		
±1% @ 68°F		DECIMAL ± .125" FRACTION ± 1/4" ANGLE ± 1°		FINISH:		

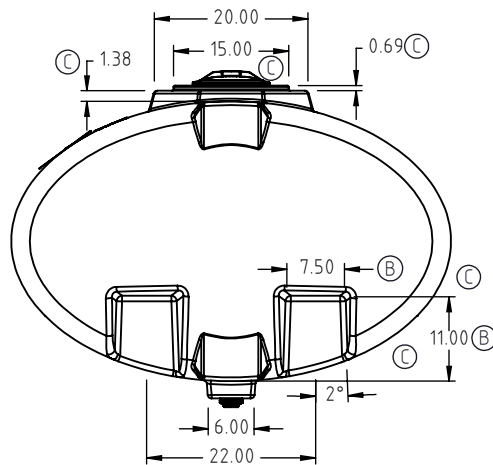
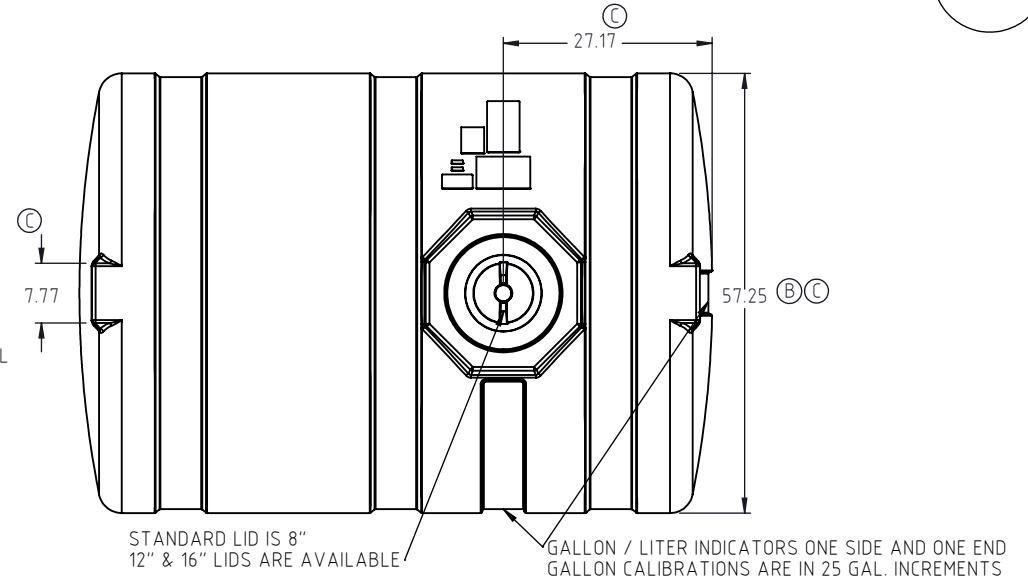
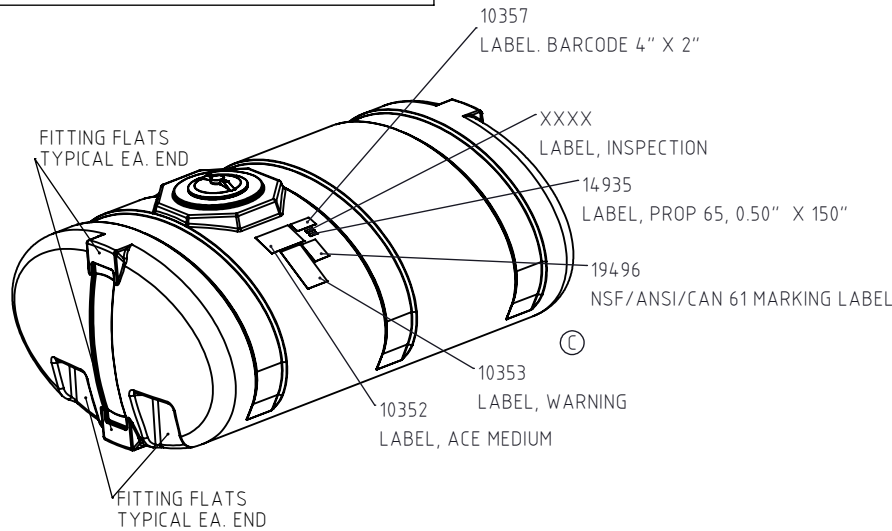

Den Hartog INDUSTRIES, INC.

Ace Roto-Mold • Injection Molding • Blow Molding • Sowjoy
4010 HOSPERS DRIVE S. BOX 425, HOSPERS, IOWA 51238-0425

DESCRIPTION HE, ELLIPTICAL 500 GAL TANK		SHEET 1 OF 1
SCALE N.S.	PART NO. HE0500-57	