

© DEN HARTOG INDUSTRIES, INC.

Copyright. All information furnished within this document, electronic file or design correspondence is the property of Den Hartog Industries, Inc. and shall not be used, disclosed to others or copied without the expressed written consent of Den Hartog Industries, Inc.

HE0600-64

FITTING FLATS TYPICAL EA. END

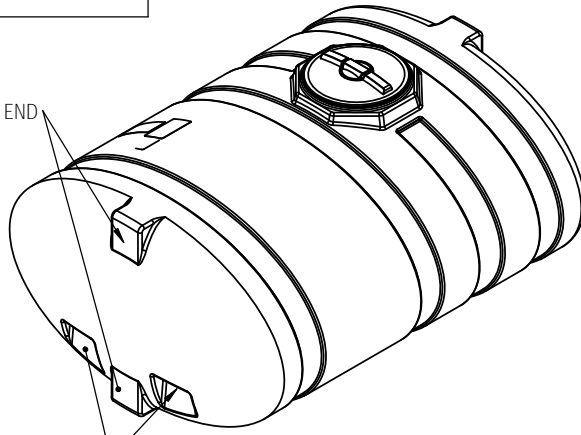

FITTING FLATS TYPICAL EA. END

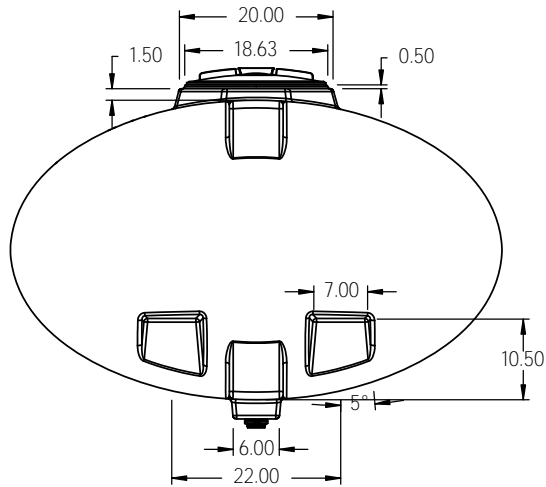

MEDIUM ACE LABEL
P.N. 10352
WARNING LABEL
P.N. 10353
BARCODE LABEL
P.N. 10357

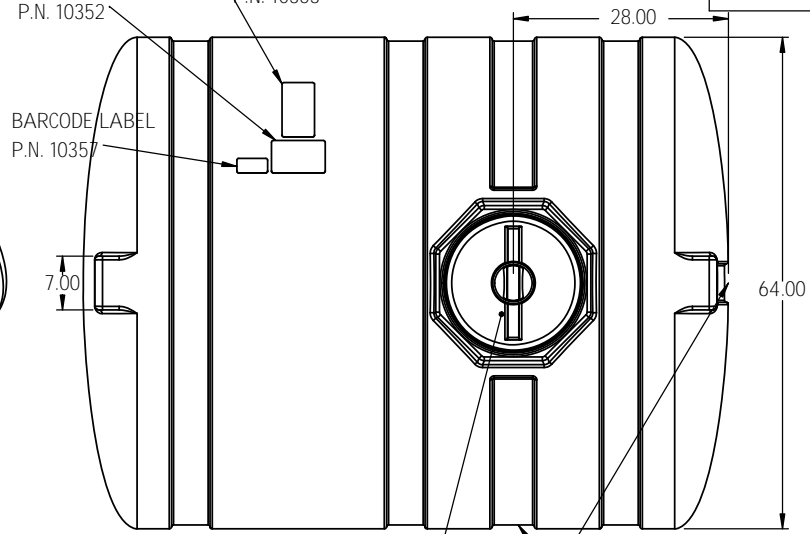

STANDARD LID IS 16"

GALLON / LITER INDICATORS BOTH SIDES AND ONE END
GALLON CALIBRATIONS ARE IN 25 GAL. INCREMENTS

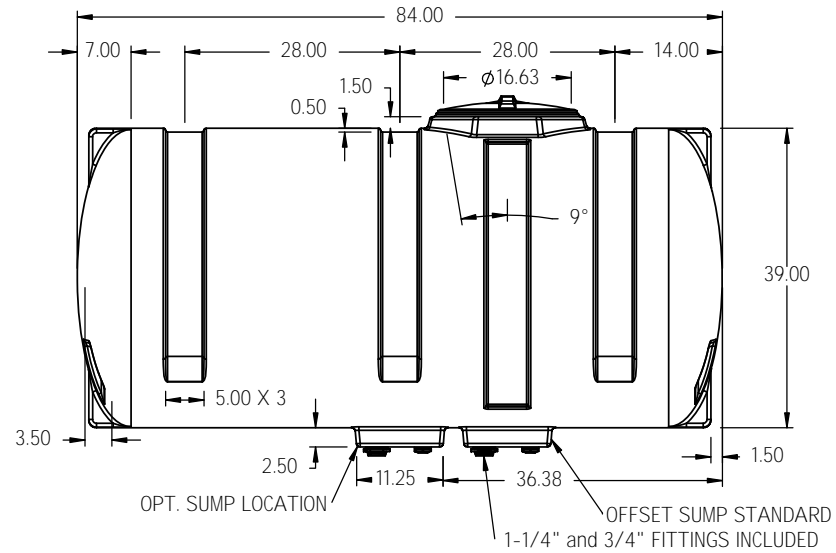

OPT. SUMP LOCATION

OFFSET SUMP STANDARD
1-1/4" and 3/4" FITTINGS INCLUDED

				DRAWN / DATE ADH 10/2/15	MATERIAL 10420
				APPRD. / DATE REH 10/2/15	
REV	DESCRIPTION	BY / DATE	CCN		
ALL DIMENSIONS ARE IN DECIMAL INCHES TOLERANCES UNLESS OTHERWISE SPECIFIED		THIRD ANGLE PROJECTION ANSI 14.5M		SHOT WEIGHT: 185.00 LBS	NOTES: 1.) 0.320 NOMINAL WALL
POLYETHYLENE		METAL DECIMAL ± .125" FRACTION ± 1/4" ANGLE ± 1°		SHIPPING WEIGHT: 187.00 LBS	
±1% @ 68°F				FINISH:	



Den Hartog
INDUSTRIES, INC.

Ace Roto-Mold Injection Molding Blow Molding Sowjoy

4010 HOSPERS DRIVE S. BOX 425, HOSPERS, IOWA 51238-0425

DESCRIPTION 600 GALLON ELLIPTICAL TANK	
SCALE N.S.	PART NO. HE0600-64