

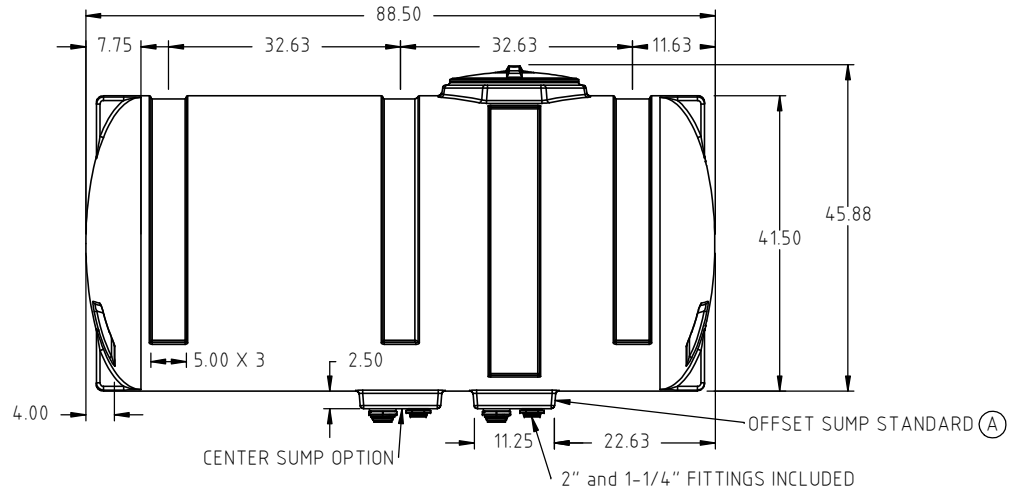

Copyright. All information furnished within this document, electronic file or design correspondence is the property of Den Hartog Industries, Inc. and shall not be used, disclosed to others or copied without the expressed written consent of Den Hartog Industries, Inc.

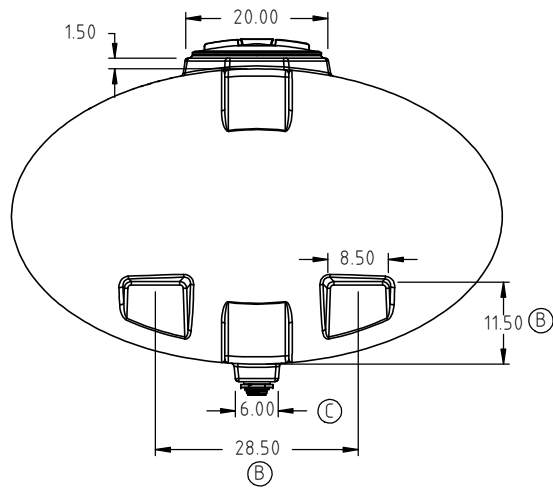

C	6.00" SUMP WIDTH CORRECTED FROM 7.00"	ADH 2/25/20	3928	DRAWN / DATE	MATERIAL POLYETHYLENE
B	11.50 WAS 14.35, 28.50 WAS 30.00	ADH 2-12-15	3012	REH 4/16/01	
A	CLARIFY STANDARD SUMP	DHJ 5-7-13	2617	APPRD. / DATE	
REV	DESCRIPTION	BY / DATE	CCN	DHJ 4/16/01	
ALL DIMENSIONS ARE IN DECIMAL INCHES TOLERANCES UNLESS OTHERWISE SPECIFIED		THIRD ANGLE PROJECTION ANSI 14.5M		SHOT WEIGHT: 220.00 LBS	NOTES: 1.) 0.330 NOMINAL WALL
POLYETHYLENE		METAL DECIMAL ± .125" FRACTION ± 1/4" ANGLE ± 1°		SHIPPING WEIGHT:	
±1% @ 68°F				FINISH:	

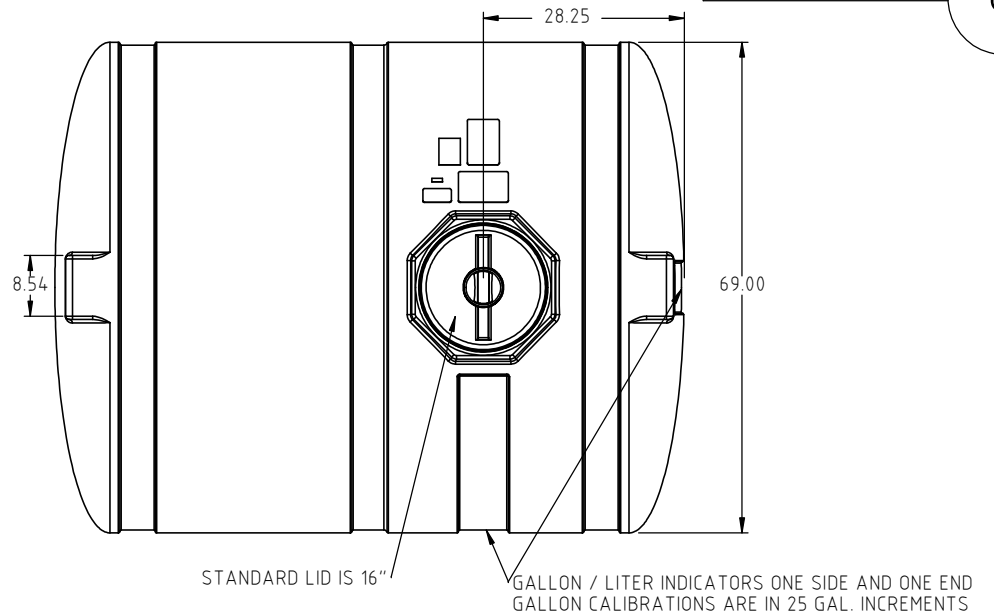
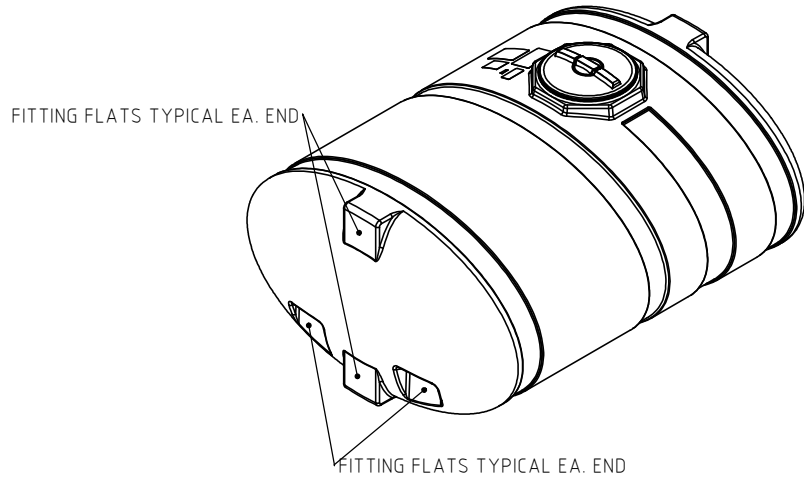

Den Hartog
INDUSTRIES, INC.

Ace Roto-Mold Injection Molding Blow Molding Sowjoy

4010 HOSPERS DRIVE S. BOX 425, HOSPERS, IOWA 51238-0425

DESCRIPTION		ACE 750 GALLON ELLIPTICAL TANK	
SCALE	N.S.	PART NO.	HE0750-69