

Copyright. All information furnished within this document, electronic file or design correspondence is the property of Den Hartog Industries, Inc. and shall not be used, disclosed to others or copied without the expressed written consent of Den Hartog Industries, Inc.

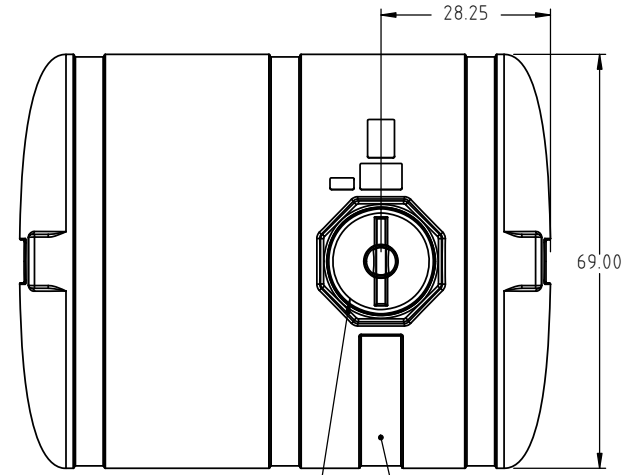

STANDARD LID IS 16" GALLON / LITER INDICATORS ONE SIDE AND ONE END GALLON CALIBRATIONS ARE IN 50 GAL. INCREMENTS

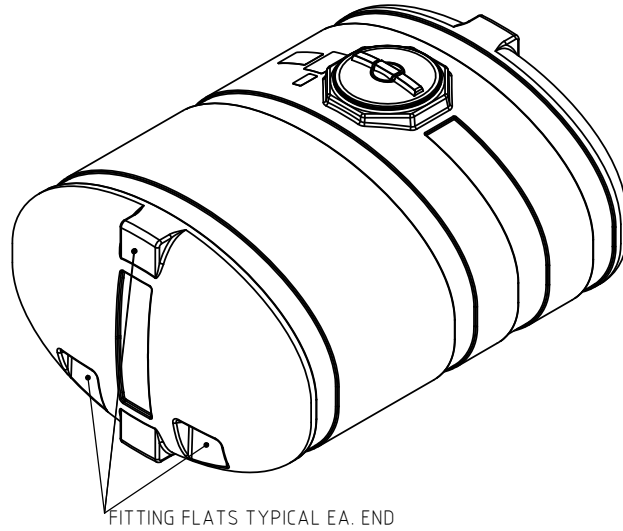
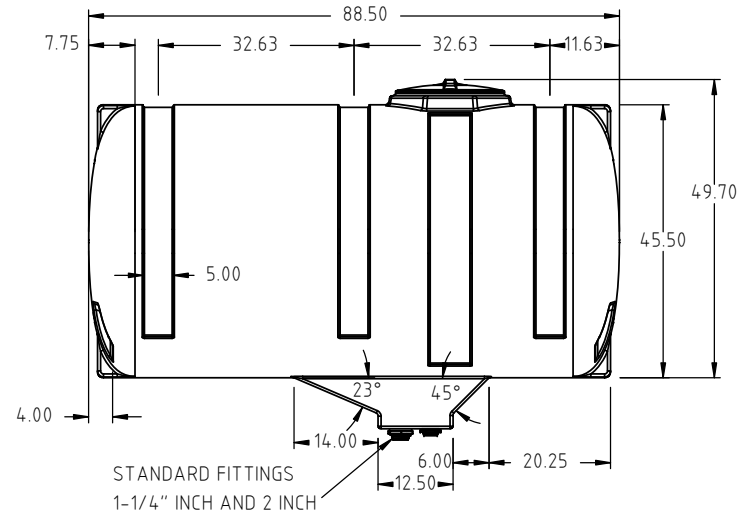
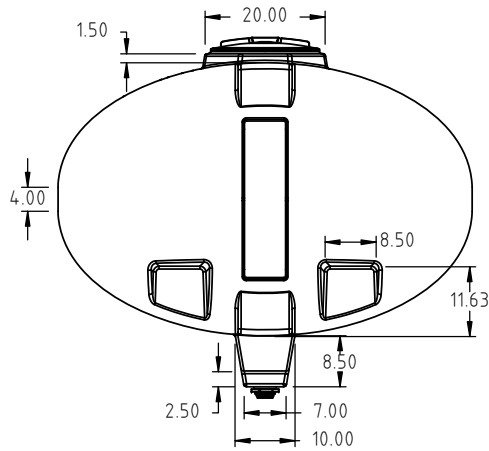

D	±1% CORRECTED FROM ±0.5%	ADH 5/8/19	3766
C	ADD 4" EXTENSION	9/1/03	
B	MOVE SUMP 11" OFF CENTER	7/9/03	
A	ADD LARGE SUMP	7/1/03	
REV	DESCRIPTION	BY / DATE	CCN

DRAWN / DATE	MATERIAL
REH 2/14/02	POLYETHYLENE
APPRD. / DATE	
ADH 11/12/07	



**Den Hartog**  
INDUSTRIES, INC.

Ace Roto-Mold Injection Molding Blow Molding Sowjoy

4010 HOSPERS DRIVE S. BOX 425, HOSPERS, IOWA 51238-0425

DESCRIPTION	850 ELLIPTICAL TANK-DEEP SUMP
SCALE	N.S.
PART NO.	HED0850-69

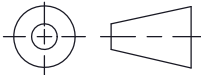
ALL DIMENSIONS ARE IN DECIMAL INCHES TOLERANCES UNLESS OTHERWISE SPECIFIED		THIRD ANGLE PROJECTION ANSI 14.5M	SHOT WEIGHT: 246.00 LBS	NOTES: 1.) 0.340 NOMINAL WALL
① POLYETHYLENE	METAL DECIMAL ± .125" FRACTION ± 1/4" ANGLE ± 1°		SHIPPING WEIGHT: 248.00 LBS	
±1% @ 68°F			FINISH:	