

Copyright. All information furnished within this document, electronic file or design correspondence is the property of Den Hartog industries, Inc. and shall not be used, disclosed to others or copied without the expressed written consent of Den Hartog Industries, Inc.

FITTING FLATS
TYPICAL EA. END

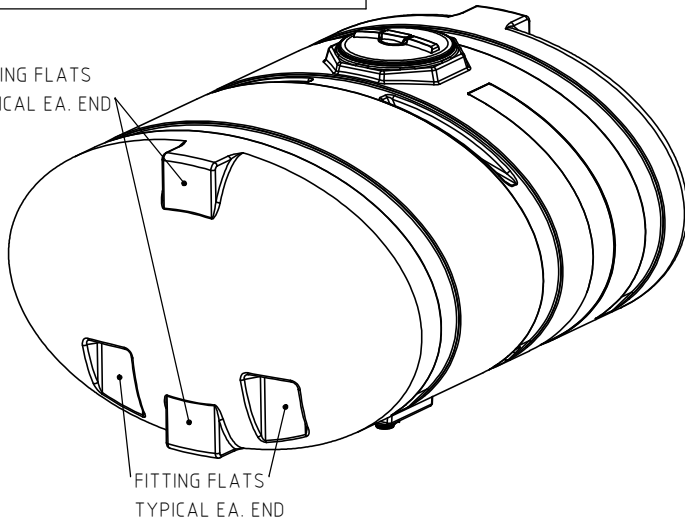

FITTING FLATS
TYPICAL EA. END

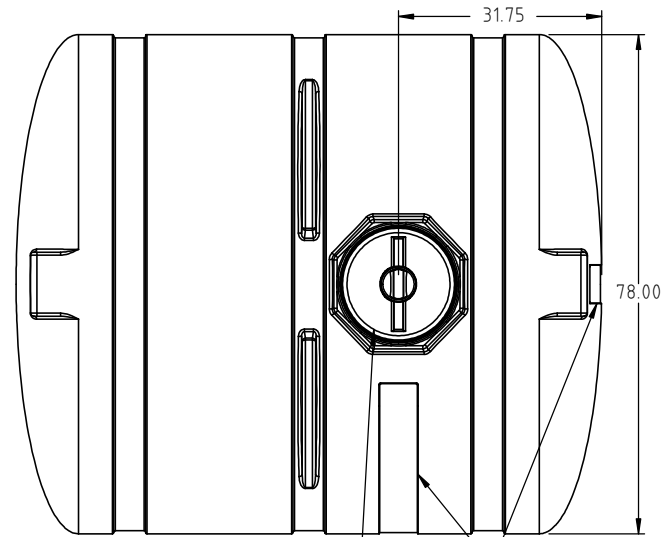
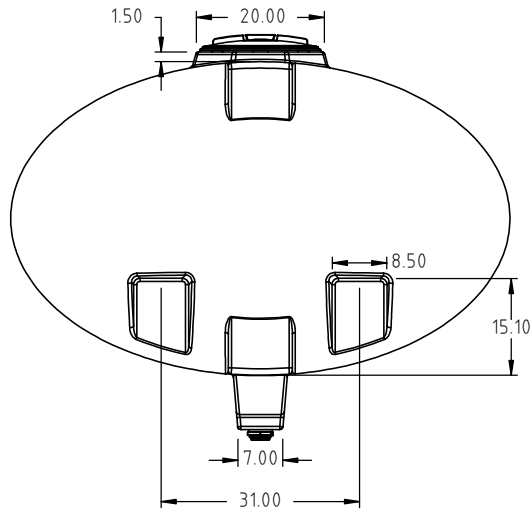

STANDARD LID IS 16"

GALLON/LITER INDICATORS ONE SIDE AND END
GALLON CALIBRATIONS ARE IN 50 GAL. INCREMENTS

B

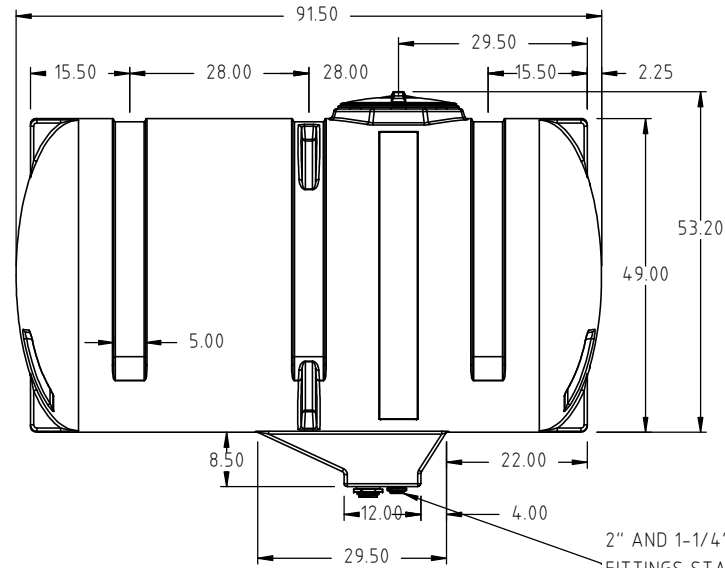

2" AND 1-1/4"
FITTINGS STANDARD

B	END GALLON/LITER INDICATOR LOCATION CORRECTED.	ADH 1/23/17	3345	DRAWN / DATE DHJ 11/12/08	MATERIAL 1.) POWDER, 3 MELT
A	UPDATE DIM.	2/6/06		APPRD. / DATE ADH 11/12/08	
REV	DESCRIPTION	BY / DATE	CCN		
ALL DIMENSIONS ARE IN DECIMAL INCHES TOLERANCES UNLESS OTHERWISE SPECIFIED		THIRD ANGLE PROJECTION ANSI 14.5M		SHOT WEIGHT: 285.00 LBS	NOTES: 1.) .330 NOMINAL WALL
POLYETHYLENE		METAL DECIMAL ± .125" FRACTION ± 1/4" ANGLE ± 1°		SHIPPING WEIGHT:	
±1% @ 68°F				FINISH:	



Den Hartog
INDUSTRIES, INC.

Ace Roto-Mold Injection Molding Blow Molding Sowjoy

4010 HOSPERS DRIVE S. BOX 425, HOSPERS, IOWA 51238-0425

DESCRIPTION ACE 1000 GALLON ELLIPTICAL TANK DEEP SUMP	
SCALE N.S.	PART NO. HED1000-78