

Copyright. All information furnished within this document, electronic file or design correspondence is the property of Den Hartog industries, Inc. and shall not be used, disclosed to others or copied without the expressed written consent of Den Hartog Industries, Inc.

KEY	PART NUMBER	DESCRIPTION	QTY.
1	HZ0095-C-1	SIDE SUPPORT PIPE	2
2	HZ0095-C-2	STAND BRACKET	4
3	HZ0095-C-3	SUPPORT STRAP	2
4	SJHZ0095C-3	PAN	2
5	SJHZ0095C-4	STRAP BRACKET	4
6	SJHZ0095C-6	CRADLE MOUNT	2

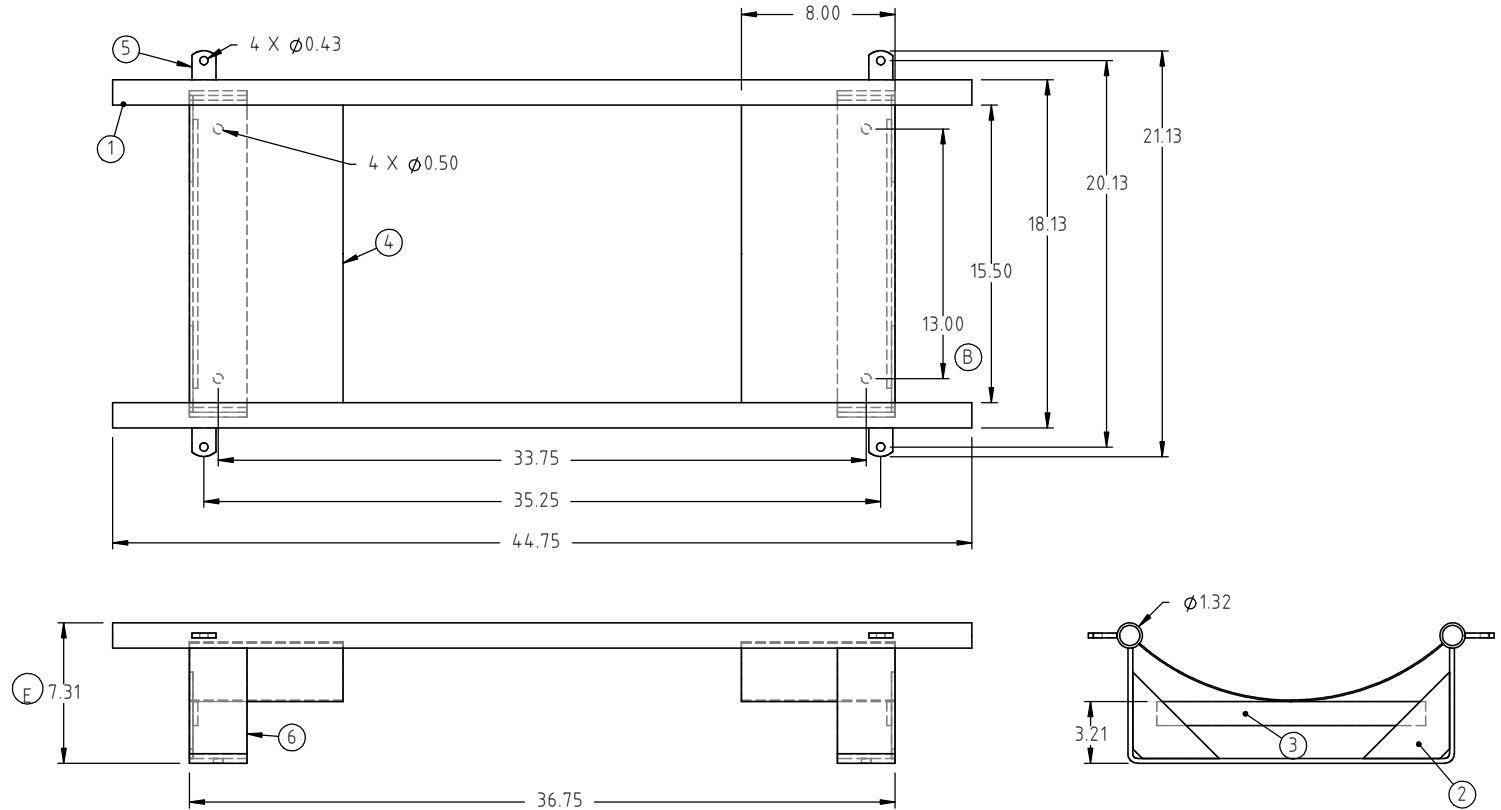

E	BAND/FITTING DETAIL REMOVED FROM PRINT. WEIGHT/FINISH ADDED TO PRINT. 7.31 WAS 7.45.	ADH 8/26/15	3115
D	DESCRIPTION CORRECTED	ADH 9/30/08	1726
C	TOLERANCE WAS 1% @ 68°F	GWC 3/14/07	
B	CHANGE HOLE SPACING WAS 12.75	2/8/05	
A	CHANGE TO POWDER COAT BANDS	2/8/05	
REV	DESCRIPTION	BY / DATE	CCN

DRAWN / DATE	MATERIAL
ADH 8/2/07	
APPRD. / DATE	
REH 11/26/07	



**Den Hartog**  
INDUSTRIES, INC.

Ace Roto-Mold Injection Molding Blow Molding Sowjoy

4010 HOSPERS DRIVE S. BOX 425, HOSPERS, IOWA 51238-0425

ALL DIMENSIONS ARE IN DECIMAL INCHES TOLERANCES UNLESS OTHERWISE SPECIFIED	
POLYETHYLENE	METAL
±1% @ 68°F	DECIMAL ± .125" FRACTION ± 1/4" ANGLE ± 1°

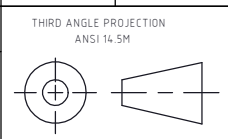

SHOT WEIGHT:	NOTES:
SHIPPING WEIGHT:	
38.00 LBS	
FINISH: POWDER COATING, BLACK TILE, 40012	

DESCRIPTION	CRADLE FOR 95 GALLON HORIZONTAL TANK	
SCALE	N.S.	PART NO. HZ0095-C

Copyright. All information furnished within this document, electronic file or design correspondence is the property of Den Hartog industries, Inc. and shall not be used, disclosed to others or copied without the expressed written consent of Den Hartog Industries, Inc.

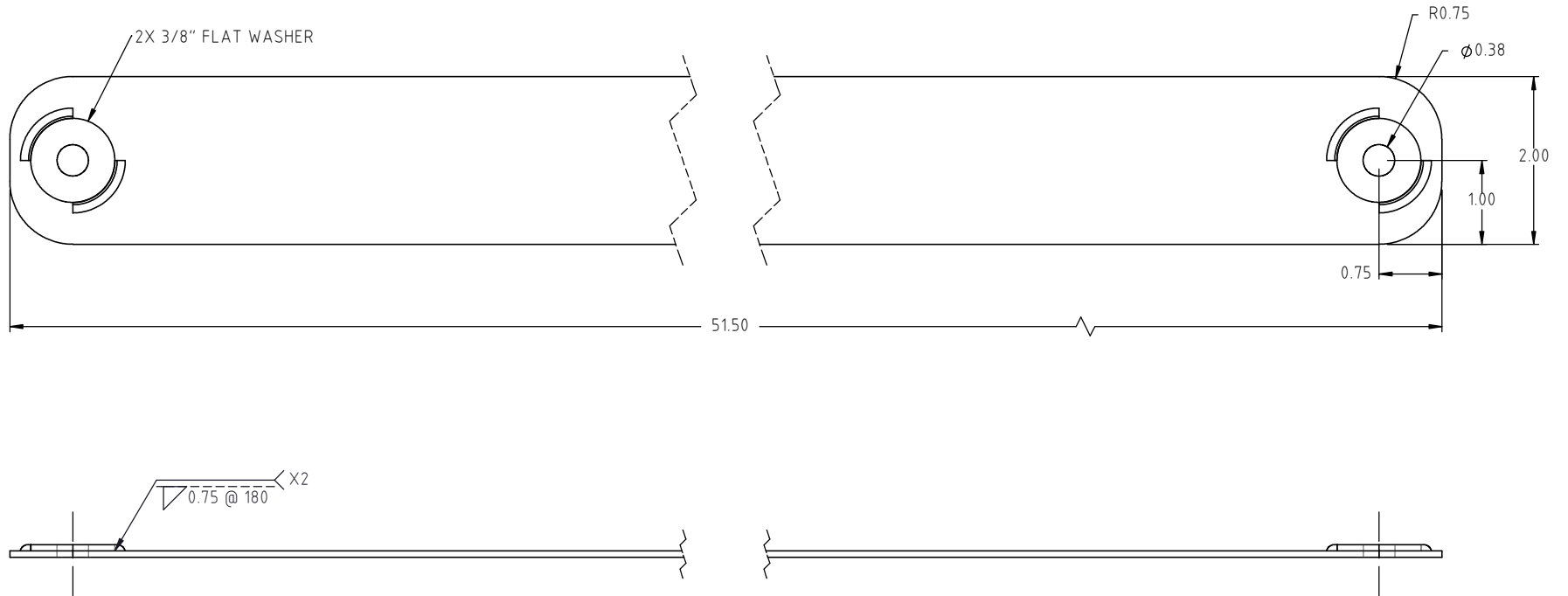

				DRAWN / DATE NVE 7/7/06	MATERIAL 14GA MILD STEEL
				APPROD. / DATE ADH 9/15/15	
REV	DESCRIPTION	BY / DATE	CCN		
ALL DIMENSIONS ARE IN DECIMAL INCHES TOLERANCES UNLESS OTHERWISE SPECIFIED		THIRD ANGLE PROJECTION ANSI 14.5M		SHOT WEIGHT:	NOTES:
POLYETHYLENE		METAL DECIMAL ± .125" FRACTION ± 1/4" ANGLE ± 1°		SHIPPING WEIGHT: 1.45 LBS.	
±1% @ 68°F				FINISH: BLACK POWDER COATED	



**Den Hartog**  
INDUSTRIES, INC.

Ace Roto-Mold Injection Molding Blow Molding Sowjoy

4010 HOSPERS DRIVE S. BOX 425, HOSPERS, IOWA 51238-0425

DESCRIPTION STEEL BAND FOR 75/95 GALLON HORIZONTAL TANKS	
SCALE N.S.	PART NO. HZ0095-CSPS