

© DEN HARTOG INDUSTRIES, INC.

Copyright. All information furnished within this document, electronic file or design correspondence is the property of Den Hartog industries, Inc. and shall not be used, disclosed to others or copied without the expressed written consent of Den Hartog Industries, Inc.

KEY	PART NUMBER	DESCRIPTION	QTY.
1	12755	ANGLE	2
2	12756	PAN SUPPORT	4
3	12757	PAN	2
4	HZ0110-C-1	MOUNT FILLER STRAP	4
5	12758	MOUNT	2

HZ0100-C

B

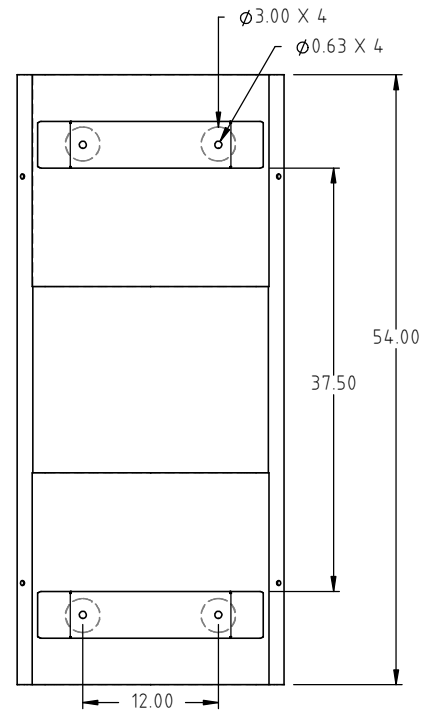
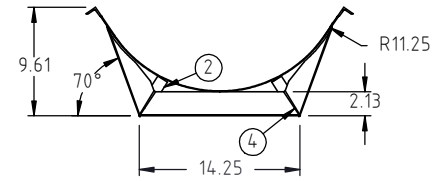
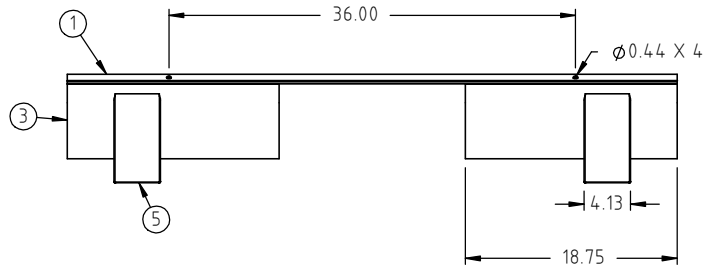

				DRAWN / DATE ADH 12/3/09	MATERIAL
B	BAND/FITTING DETAIL REMOVED FROM PRINT. DRAWING TEMPLATE UPDATED.	ADH 8/26/15	3115	APPRD. / DATE REH 1/14/10	
A	41.50" WAS 40.00"	ADH 1/10/12	2556		
REV	DESCRIPTION	BY / DATE	CCN		
ALL DIMENSIONS ARE IN DECIMAL INCHES TOLERANCES UNLESS OTHERWISE SPECIFIED		THIRD ANGLE PROJECTION ANSI 14.5M		SHOT WEIGHT:	NOTES:
POLYETHYLENE		METAL DECIMAL ± .125" FRACTION ± 1/4" ANGLE ± 1°		SHIPPING WEIGHT: SEE NOTES	CRADLE = 36.00 LBS.
±1% @ 68°F				FINISH: POWDER COATING, BLACK TILE, 40012	CRADLE WITH BANDS AND BOLT BAG = 40.00 LBS.



Den Hartog
INDUSTRIES, INC.

Ace Roto-Mold Injection Molding Blow Molding Sowjoy

4010 HOSPERS DRIVE S. BOX 425, HOSPERS, IOWA 51238-0425

DESCRIPTION	HZ, CRADLE, 100 GALLON	
SCALE	N.S.	PART NO. HZ0100-C

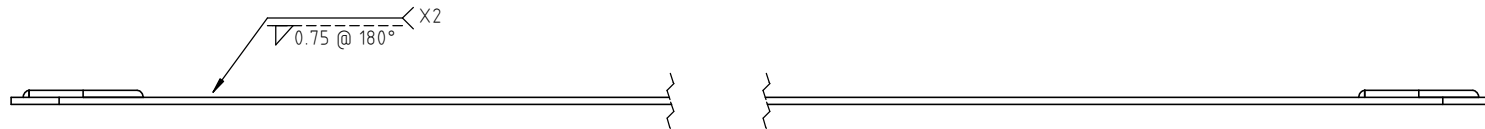
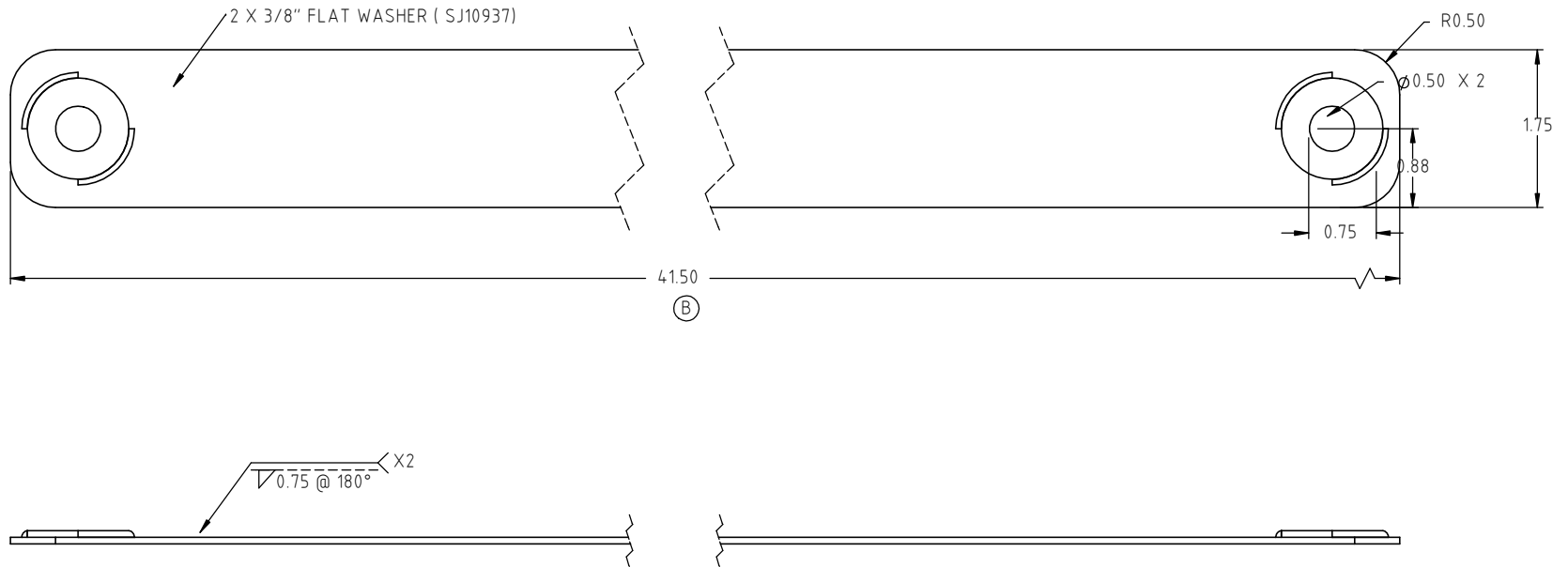

				DRAWN / DATE ADH 1/11/10	MATERIAL (A) 1.) 14 GA MILD STEEL, 1.75 X 4.150
B	4.150" WAS 40.50"	ADH 1/10/12	2556	APPROD. / DATE REH 1/14/10	
A	40.00" WAS SHOWN AS 39.50"	ADH 6/15/12	2437		
REV	DESCRIPTION	BY / DATE	CCN		
ALL DIMENSIONS ARE IN DECIMAL INCHES TOLERANCES UNLESS OTHERWISE SPECIFIED		THIRD ANGLE PROJECTION ANSI 14.5M		SHOT WEIGHT: SINGLE BAND 1.50 LBS	NOTES: 1.) 5/16" X 3" J BOLTS REQUIRED X 2 PER BAND (BOLT BAG= BBS/16X3BAG-4)
POLYETHYLENE ±1% @ 68°F	METAL DECIMAL ± .125" FRACTION ± 1/4" ANGLE ± 1°			FINISH: POWDER COATING, BLACK TILE, 40012	



Den Hartog
INDUSTRIES, INC.

Ace Roto-Mold Injection Molding Blow Molding Sowjoy

4010 HOSPERS DRIVE S. BOX 425, HOSPERS, IOWA 51238-0425

DESCRIPTION	HZ, STEEL BAND, 100 GALLON , 1.75 X 3.50	
SCALE	N.S.	PART NO. HZ0100-CSPS