

© DEN HARTOG INDUSTRIES, INC.

Copyright. All information furnished within this document, electronic file or design correspondence is the property of Den Hartog Industries, Inc. and shall not be used, disclosed to others or copied without the expressed written consent of Den Hartog Industries, Inc.

KEY	PART NUMBER	DESCRIPTION	QTY.
1	HZ0110-C-1	MOUNT FILLER STRAP	4
2	HZ0110-C-2	PAN SUPPORT/MOUNT FILLER	4
3	SJHZ0110C-1	ANGLE STEEL	2
4	SJHZ01110C-3	PAN	2
5	SJHZ0110C-6	CRADLE MOUNT	2

HZ0110-C

D

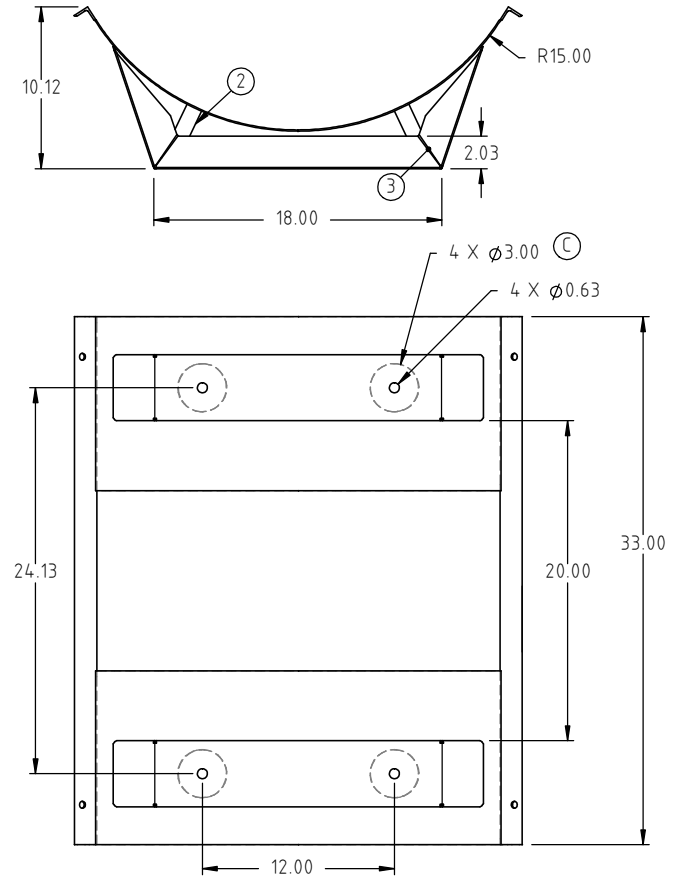
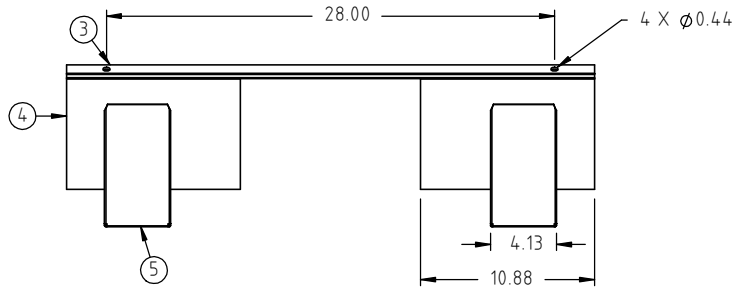

D	WEIGHT/FINISH ADDED, DRAWING TEMPLATE UPDATED. BAND DETAIL REMOVED FROM PRINT.	ADH 8/26/15	3115		
C	3" PAN ACCESS HOLES ADDED	ADH 4/22/09	1858	DRAWN / DATE ADH 8/7/07	MATERIAL
B	TOLERANCE WAS 1% @ 68°F	GWC 3/14/07		APPROD. / DATE REH 11/26/07	
A	BAND LENGTH WAS 59	4/10/06			
REV	DESCRIPTION	BY / DATE	CCN		
ALL DIMENSIONS ARE IN DECIMAL INCHES TOLERANCES UNLESS OTHERWISE SPECIFIED		THIRD ANGLE PROJECTION ANSI 14.5M		SHOT WEIGHT:	
POLYETHYLENE		METAL		SHIPPING WEIGHT:	
±1% @ 68°F		DECIMAL ± .125" FRACTION ± 1/4" ANGLE ± 1°		D 4.00 LBS	
		D		FINISH: POWDER COATING, BLACK	
		D		TILE, 40012	



**Den Hartog**  
INDUSTRIES, INC.

Ace Roto-Mold Injection Molding Blow Molding Sowjoy

4010 HOSPERS DRIVE S. BOX 425, HOSPERS, IOWA 51238-0425

DESCRIPTION	CRADLE FOR 110 GALLON HORIZONTAL TANK	
SCALE	N.S.	PART NO. HZ0110-C

Copyright. All information furnished within this document, electronic file or design correspondence is the property of Den Hartog industries, Inc. and shall not be used, disclosed to others or copied without the expressed written consent of Den Hartog Industries, Inc.

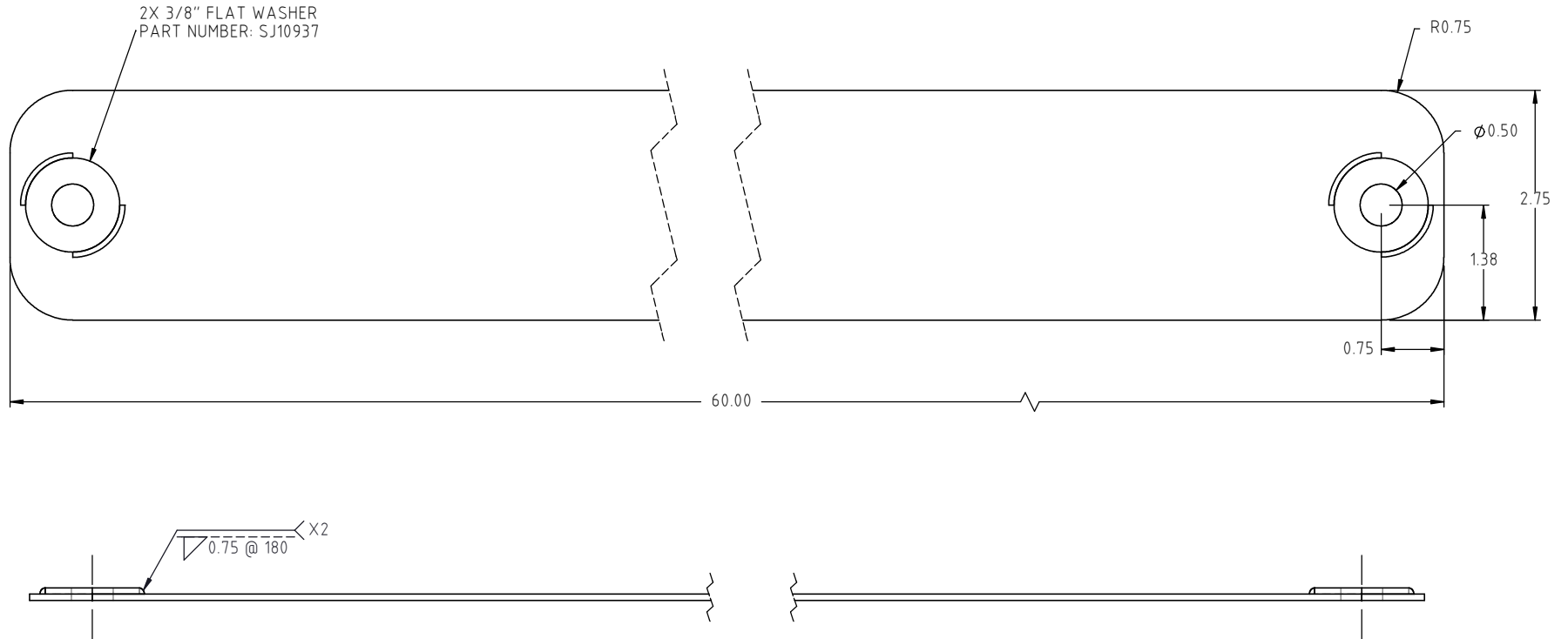

				DRAWN / DATE NVE 7/7/06	MATERIAL 14GA MILD STEEL,
				APPROD. / DATE ADH 3/17/16	
REV	DESCRIPTION	BY / DATE	CCN	SHOT WEIGHT:	NOTES:
				SHIPPING WEIGHT: 3.54 LBS.	
				FINISH: BLACK POWDER COATED	



**Den Hartog**  
INDUSTRIES, INC.

Ace Roto-Mold Injection Molding Blow Molding Sowjoy

4010 HOSPERS DRIVE S. BOX 425, HOSPERS, IOWA 51238-0425

DESCRIPTION  
STEEL BAND FOR 110 GALLON HORIZONTAL TANKS

SCALE  
N.S.

PART NO.  
HZ0110-CSPS

THIRD ANGLE PROJECTION  
ANSI 14.5M

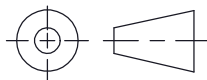

ALL DIMENSIONS ARE IN DECIMAL INCHES  
TOLERANCES UNLESS OTHERWISE SPECIFIED

POLYETHYLENE  
±1% @ 68°F

METAL  
DECIMAL ± .125"  
FRACTION ± 1/4"  
ANGLE ± 1°