

© DEN HARTOG INDUSTRIES, INC.

Copyright. All information furnished within this document, electronic file or design correspondence is the property of Den Hartog Industries, Inc. and shall not be used, disclosed to others or copied without the expressed written consent of Den Hartog Industries, Inc.

KEY	PART NUMBER	DESCRIPTION	QTY.
1	HZ0238-C-1	SIDE PANEL	2
2	HZ0238-C-2	BASE STRAP	2
3	HZ0238-C-3	PAN SUPPORT STRAP	4
4	SJHZ0238C-1	ANGLE PAN TOP	2
5	SJHZ0238C-2	BASE ANGLE	2
6	SJHZ0238C-3	CRADLE PAN	2

HZ0238-C

D

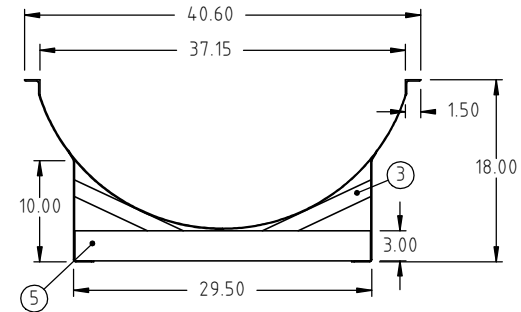
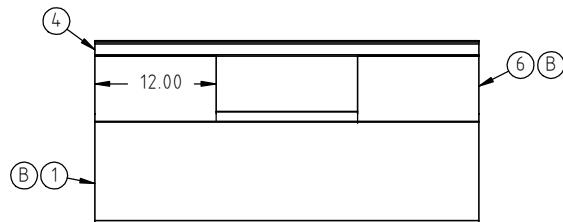
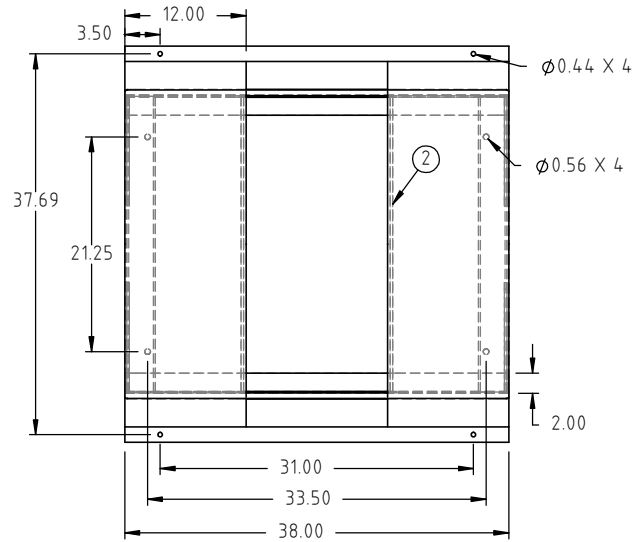

D	BAND DETAIL REMOVED FROM PRINT.	ADH 8/26/15	3115		
C	3/8"X3-3/4" J BOLTS WERE 5/16"X3" J BOLTS DRAWING TEMPLATE UPDATED	ADH 1/10/13	2556	DRAWN / DATE	MATERIAL
B	PART NUMBERS CORRECTED	ADH 1/22/08	1573	ADH 8/13/07	
A	TOLERANCE WAS 1% @ 68°F	GWC 3/14/07		APPRD. / DATE	
REV	DESCRIPTION	BY / DATE	CCN	REH 11/26/07	
ALL DIMENSIONS ARE IN DECIMAL INCHES TOLERANCES UNLESS OTHERWISE SPECIFIED		THIRD ANGLE PROJECTION ANSI 14.5M		SHOT WEIGHT:	NOTES:
POLYETHYLENE		METAL DECIMAL ± .125" FRACTION ± 1/4" ANGLE ± 1°		SHIPPING WEIGHT: 85 LBS	
±1% @ 68°F				FINISH: POWDER COATING, BLACK TILE, 40012	



Den Hartog
INDUSTRIES, INC.

Ace Roto-Mold Injection Molding Blow Molding Sowjoy

4010 HOSPERS DRIVE S. BOX 425, HOSPERS, IOWA 51238-0425

DESCRIPTION	
CRADLE ASSEMBLY FOR 200 GALLON ϕ 38 HORIZONTAL TANK	
SCALE	PART NO.
N.S.	HZ0238-C

Copyright. All information furnished within this document, electronic file or design correspondence is the property of Den Hartog Industries, Inc. and shall not be used, disclosed to others or copied without the expressed written consent of Den Hartog Industries, Inc.

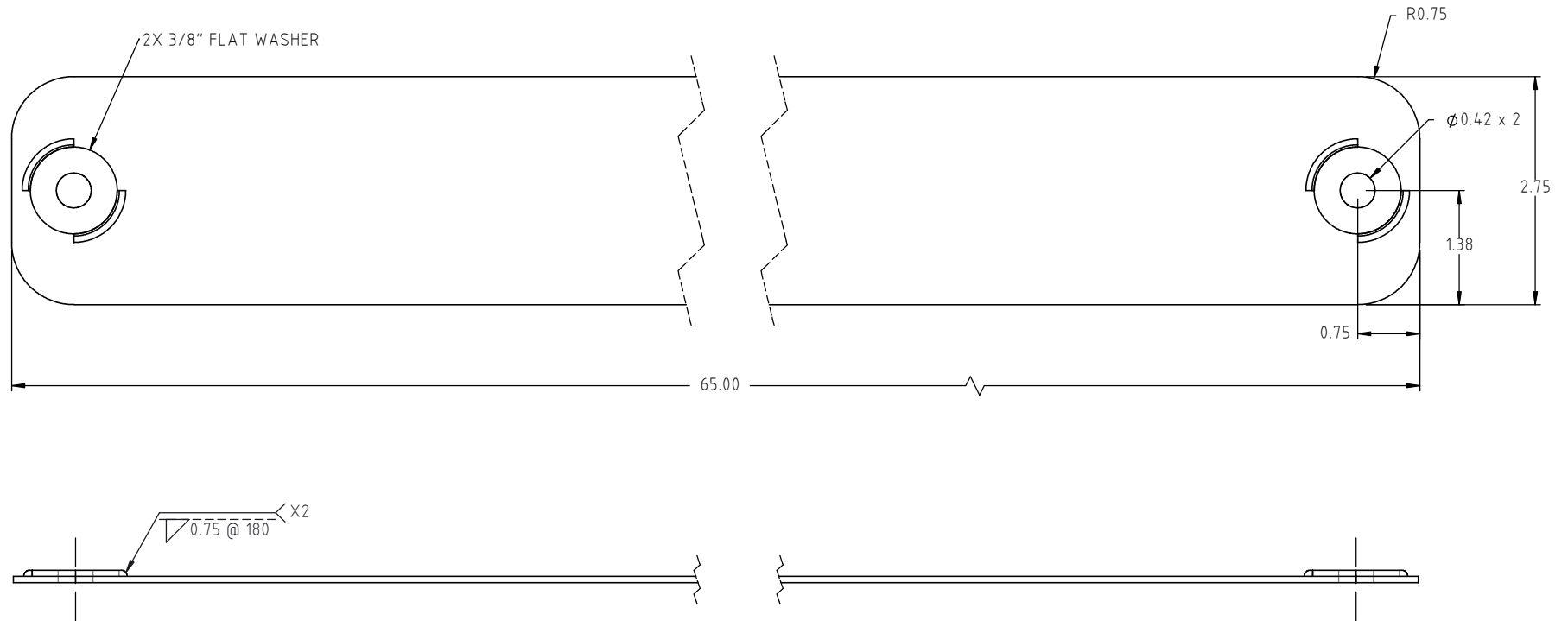

				DRAWN / DATE NVE 7/7/06	MATERIAL 14GA MILD STEEL,
				APPRO. / DATE ADH 12/27/12	
REV	DESCRIPTION	BY / DATE	CCN		
ALL DIMENSIONS ARE IN DECIMAL INCHES TOLERANCES UNLESS OTHERWISE SPECIFIED		THIRD ANGLE PROJECTION ANSI 14.5M		SHOT WEIGHT:	NOTES:
POLYETHYLENE		METAL DECIMAL ± .125" FRACTION ± 1/4" ANGLE ± 1°		SHIPPING WEIGHT: 3.91 LBS.	
±1% @ 68°F				FINISH: BLACK POWDER COATED	



Den Hartog
INDUSTRIES, INC.

Ace Roto-Mold Injection Molding Blow Molding Sowjoy

4010 HOSPERS DRIVE S. BOX 425, HOSPERS, IOWA 51238-0425

DESCRIPTION STEEL BAND FOR 200 GALLON, ϕ 38" HORIZONTAL TANKS	
SCALE N.S.	PART NO. HZ0238-CSPS