

				DRAWN / DATE ADH 6/2/15	MATERIAL
				APPROD. / DATE REH 7/16/15	
REV	DESCRIPTION	BY / DATE	CCN		
ALL DIMENSIONS ARE IN DECIMAL INCHES TOLERANCES UNLESS OTHERWISE SPECIFIED		THIRD ANGLE PROJECTION ANSI 14.5M		SHOT WEIGHT:	NOTES:
POLYETHYLENE		METAL DECIMAL ± .125" FRACTION ± 1/4" ANGLE ± 1°		SHIPPING WEIGHT:	
±1% @ 68°F				FINISH:	



Den Hartog
INDUSTRIES, INC.

Ace Roto-Mold Injection Molding Blow Molding Sowjoy

4010 HOSPERS DRIVE S. BOX 425, HOSPERS, IOWA 51238-0421

DESCRIPTION 15 GALLON BLOW MOLDED INDUCTOR AND LEGS	
SCALE N.S.	PART NO. IBFD15-SET

Copyright. All information furnished within this document, electronic file or design correspondence is the property of Den Hartog Industries, Inc. and shall not be used, disclosed to others or copied without the expressed written consent of Den Hartog Industries, Inc.

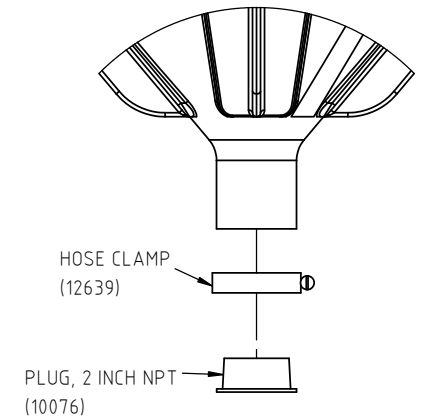
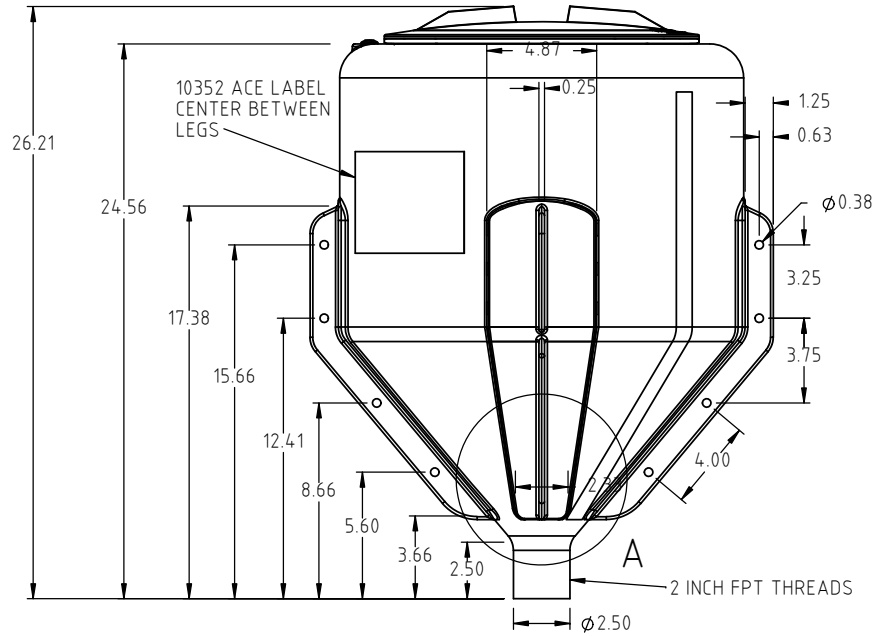
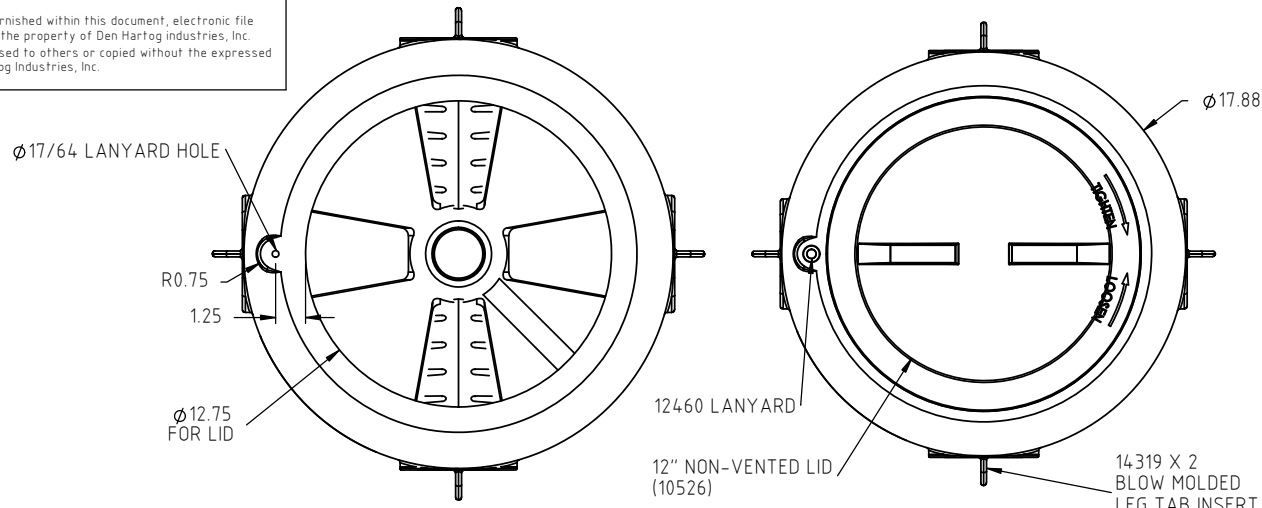

				DRAWN / DATE ADH 6/2/15	MATERIAL 80001 PELLETS
				APPRD. / DATE REH 7/16/15	
REV	DESCRIPTION	BY / DATE	CCN		
ALL DIMENSIONS ARE IN DECIMAL INCHES TOLERANCES UNLESS OTHERWISE SPECIFIED		THIRD ANGLE PROJECTION ANSI 14.5M		SHOT WEIGHT: 6.9 LB	NOTES: 1. .140 WALL
POLYETHYLENE		METAL DECIMAL ± .125" FRACTION ± 1/4" ANGLE ± 1°		SHIPPING WEIGHT:	
±1% @ 68°F				FINISH:	



Den Hartog
INDUSTRIES, INC.

Ace Roto-Mold Injection Molding Blow Molding Sowjoy

4010 HOSPERS DRIVE S. BOX 425, HOSPERS, IOWA 51238-0421

DESCRIPTION 15 GALLON BLOW MOLDED INDUCTOR TANK ASSEMBLY	
SCALE N.S.	PART NO. IBFD015-SWSS

Copyright. All information furnished within this document, electronic file or design correspondence is the property of Den Hartog Industries, Inc. and shall not be used, disclosed to others or copied without the expressed written consent of Den Hartog Industries, Inc.

BLOW MOLDED 10,15,20 GALLON INDUCTOR TANK (IBFD010-SWSS SHOWN)
 IBFD010-SWSS
 IBFD015-SWSS
 IBFD020-SWSS

IBFD10-15-20-ASSY

ASSEMBLY INSTRUCTIONS:

- 1.) UNPACK INDUCTOR COMPONENTS. YOU SHOULD HAVE THE INDUCTOR TANK ASSEMBLY, FOUR LEGS AND ONE HARDWARE BAG. A TOTAL OF SIX PIECES ARE INCLUDED IN THE BOX.
- 2.) TO INSTALL THE LEGS IT IS RECOMMENDED THAT THE INDUCTOR BE PLACED ON ONE SIDE. FASTEN EACH LEG AS SHOWN WITH FOUR(4) 5/16" X 1-1/4" BOLTS, TWO (2) FLAT WASHERS AND ONE (1) LOCKNUT. DO NOT TIGHTEN ANY BOLTS AT THIS TIME.
- 3.) AFTER ALL FOUR LEGS ARE LOOSELY INSTALLED, TIP INDUCTOR UPRIGHT ON THE LEGS TO LEVEL THEM. TIGHTEN EACH BOLT UNTIL SNUG.
- 4.) INDUCTORS ARE SHIPPED WITH A PLUG IN THE OUTLET TO PROTECT THE THREADS. LOOSEN HOSE CLAMP, REMOVE SHIPPING PLUG AND REPLACE WITH A 2" NPT THREADED FITTING OF YOUR CHOICE. USE TEFLON TAPE ON THE THREADS. THREAD FITTING IN UNTIL JUST SNUG. DO NOT OVER TIGHTEN! SECURE CONNECTION WITH HOSE CLAMP PROVIDED.
- 5.) BEFORE USE IT IS RECOMMENDED THAT INDUCTOR BE CHECKED FOR LEAKS, RINSED OUT AND DRIED.
- 6.) INDUCTORS THAT ARE TO BE TRANSPORTED MUST HAVE THE OPTIONAL 12695 ANCHOR KIT INSTALLED AS ILLUSTRATED AND SECURELY FASTENED IN PLACE.
- 7.) INDUCTOR TANKS ARE DESIGNED FOR CONTAINMENT OF LIQUIDS UP TO 1.7 SPECIFIC GRAVITY (1.7 TIMES THE WEIGHT OF WATER).

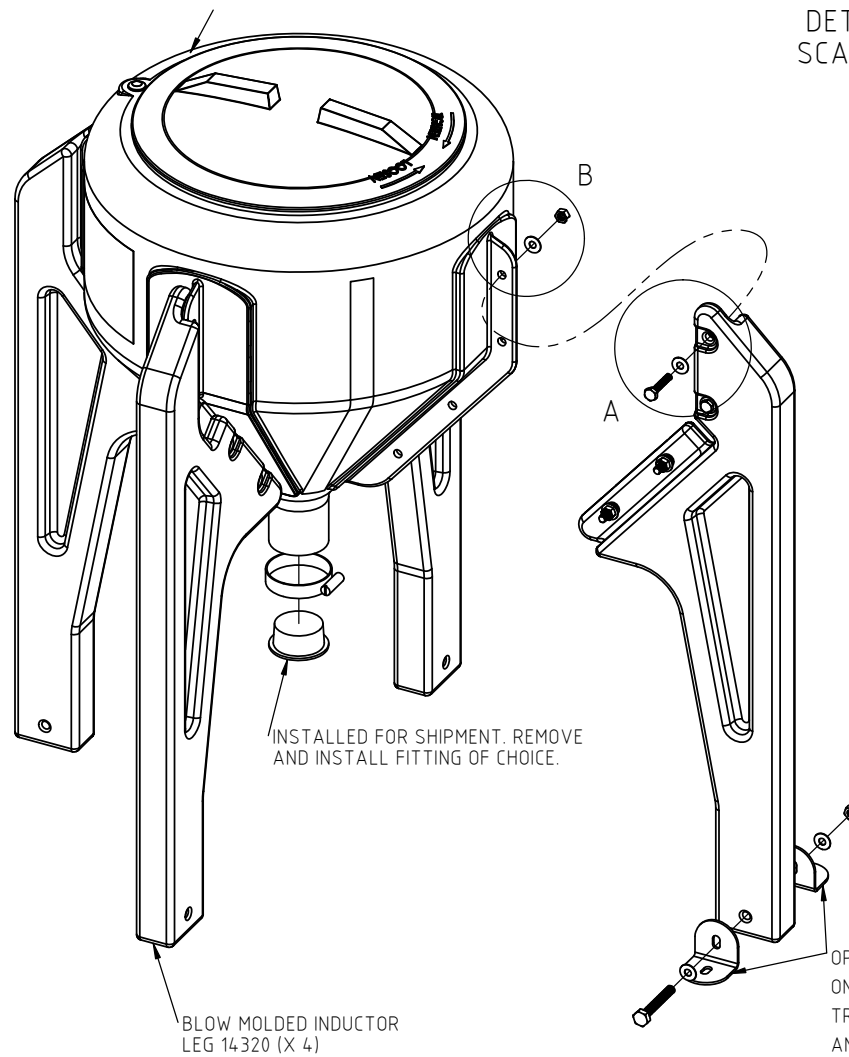

DETAIL B
SCALE 1:4

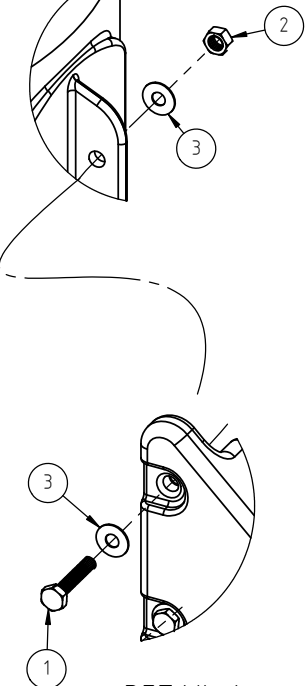

DETAIL A
SCALE 1:4

OPTIONAL LEG ANCHOR REQUIRED ON EACH LEG IF INDUCTOR IS TO BE TRANSPORTED. ORDER 12695 LEG ANCHOR KIT.

10, 15, 20 GALLON INDUCTOR HARDWARE BAG 14358

KEY	PART NUMBER	DESCRIPTION	QTY.
1	SJ10031	BOLT, 5/16" X 1-1/2" SS	16
2	SJ10011	NUT, 5/16" NYLOK SS	16
3	SJ11095	WASHER, 5/16" FLAT SS	32
4	IBFD10-15-20-ASSY	10,15,20 GAL. ASSY. INSTRUCTIONS	1

				DRAWN / DATE ADH 5/6/15	MATERIAL
				APPROD. / DATE REH 7/16/15	
REV	DESCRIPTION	BY / DATE	CCN		
ALL DIMENSIONS ARE IN DECIMAL INCHES TOLERANCES UNLESS OTHERWISE SPECIFIED		THIRD ANGLE PROJECTION ANSI 14.5M		SHOT WEIGHT:	NOTES:
POLYETHYLENE		METAL DECIMAL ± .125" FRACTION ± 1/4" ANGLE ± 1°		SHIPPING WEIGHT:	
±1% @ 68°F				FINISH:	



Den Hartog
INDUSTRIES, INC.

Ace Roto-Mold Injection Molding Blow Molding Sowjoy

4010 HOSPERS DRIVE S. BOX 425, HOSPERS, IOWA 51238-0425

DESCRIPTION 10,15,20 GALLON BLOW MOLDED INDUCTOR ASSEMBLY INSTRUCTIONS	
SCALE N.S.	PART NO. IBFD10-15-20-ASSY

Copyright. All information furnished within this document, electronic file or design correspondence is the property of Den Hartog Industries, Inc. and shall not be used, disclosed to others or copied without the expressed written consent of Den Hartog Industries, Inc.

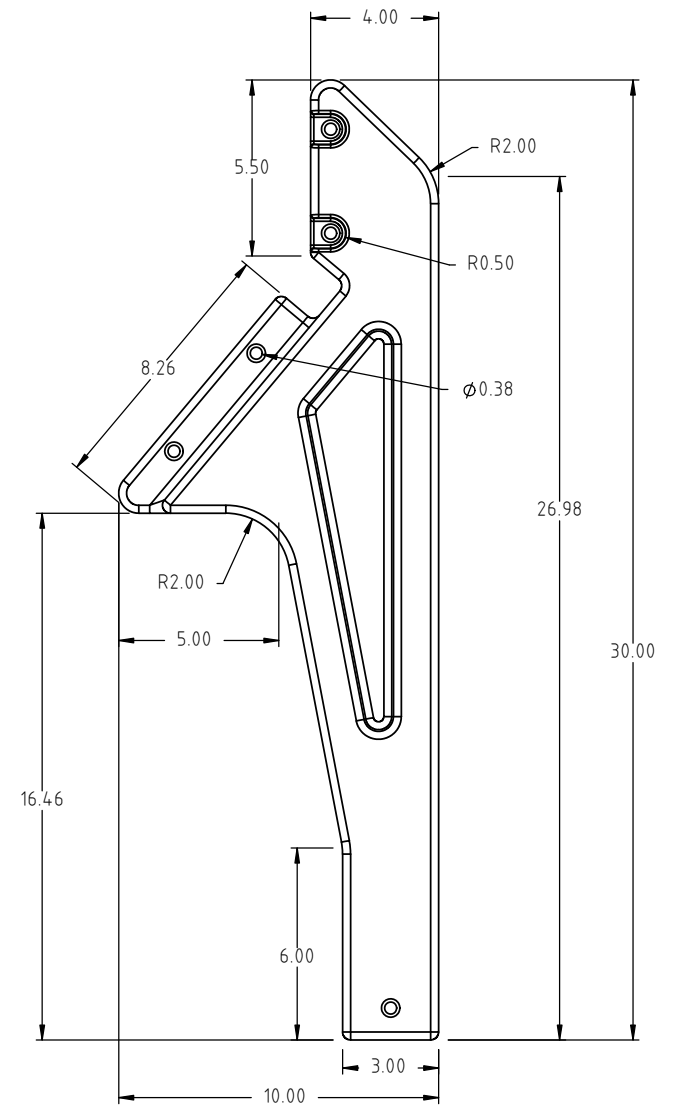
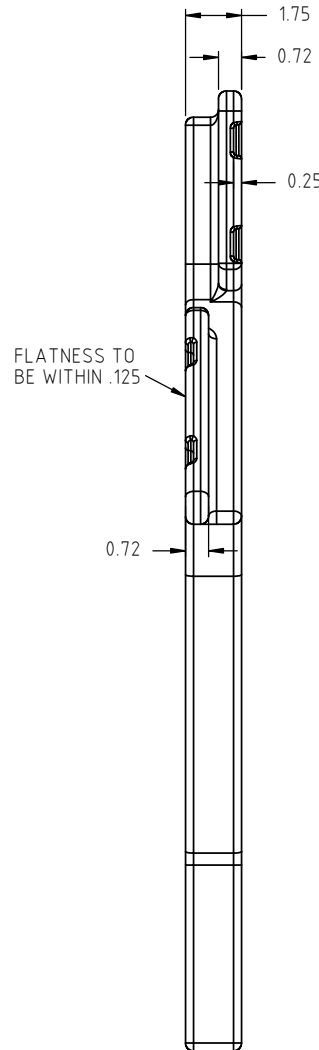
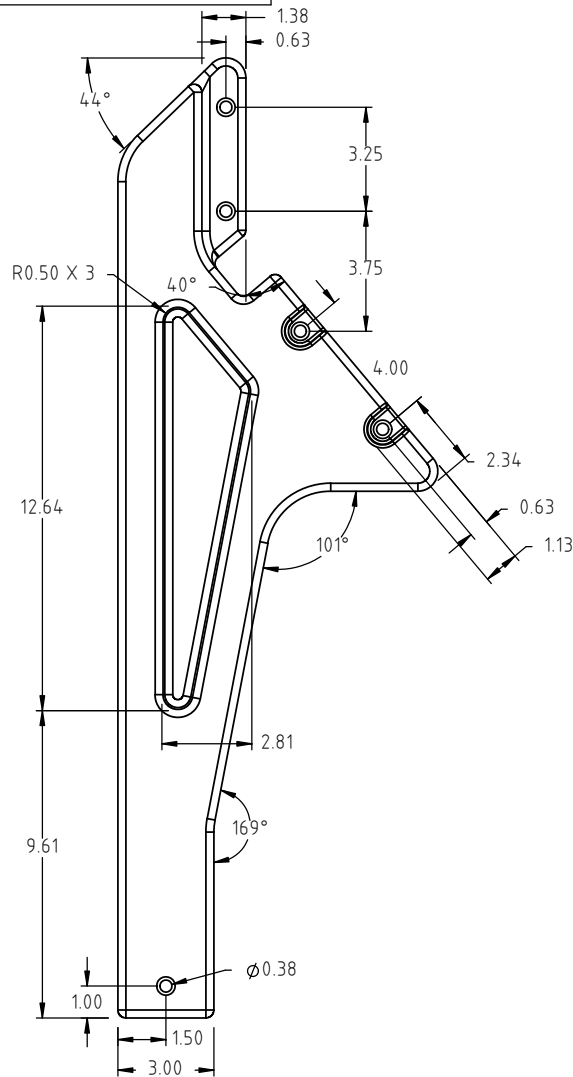

				DRAWN / DATE ADH 5/5/15	MATERIAL 80041 / 80007
				APPRD. / DATE REH 7/16/15	
REV	DESCRIPTION	BY / DATE	CCN	SHOT WEIGHT: 2.0 LB.	NOTES: 1.) .150 WALL THICKNESS
				SHIPPING WEIGHT: 2.0 LB.	
ALL DIMENSIONS ARE IN DECIMAL INCHES TOLERANCES UNLESS OTHERWISE SPECIFIED POLYETHYLENE ±1% @ 68°F		THIRD ANGLE PROJECTION ANSI 14.5M 		FINISH:	



Den Hartog
INDUSTRIES, INC.

Ace Roto-Mold Injection Molding Blow Molding Sowjoy

4010 HOSPERS DRIVE S. BOX 425, HOSPERS, IOWA 51238-0421

DESCRIPTION BLOW MOLDED LEG - SHORT	
SCALE N.S.	PART NO. 14320

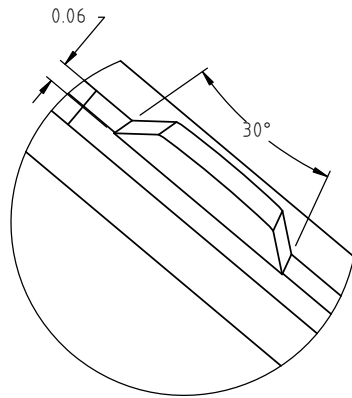
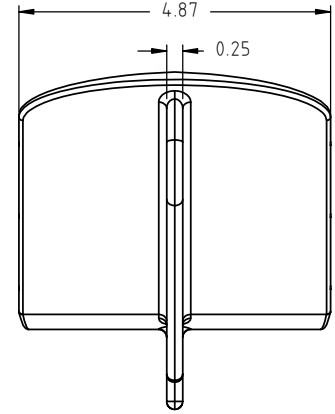
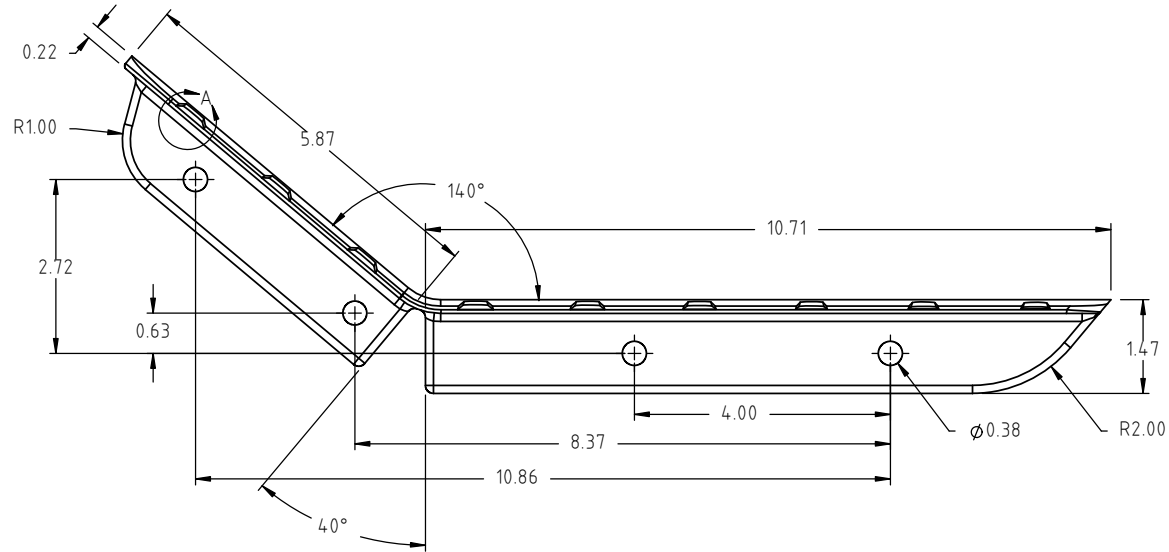
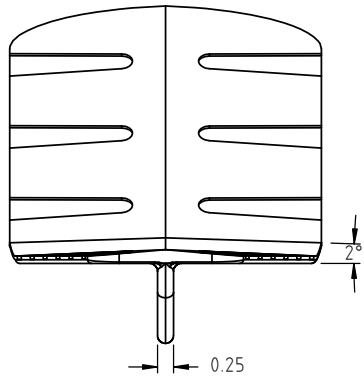

DETAIL A
SCALE 2 : 1

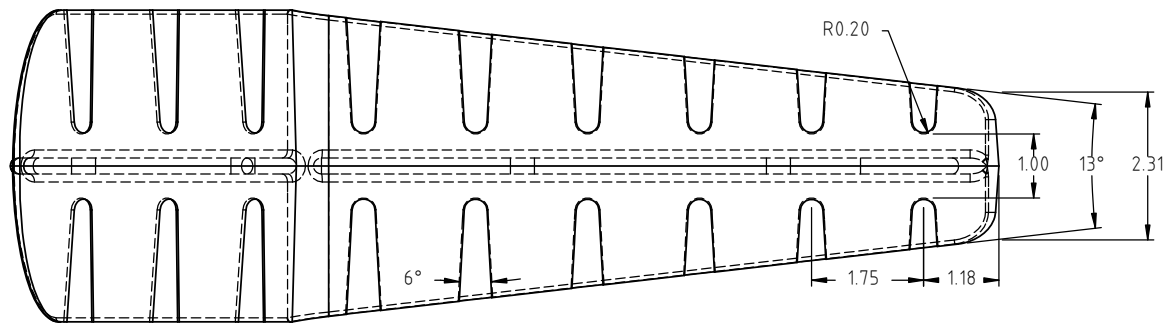

REV	DESCRIPTION	BY / DATE	CCN	DRAWN / DATE ADH 5/6/15	MATERIAL NATURAL HDPE
				APPRD. / DATE REH 7/16/15	
				SHOT WEIGHT: 53 LBS.	NOTES: 1. NATURAL COLOR
				SHIPPING WEIGHT:	
				FINISH: MACHINED	



Den Hartog
INDUSTRIES, INC.

Ace Roto-Mold Injection Molding Blow Molding Sowjoy

4010 HOSPERS DRIVE S. BOX 425, HOSPERS, IOWA 51238-0425

DESCRIPTION LEG INSERT TAB - SHORT	
SCALE N.S.	PART NO. 14319

ALL DIMENSIONS ARE IN DECIMAL INCHES
TOLERANCES UNLESS OTHERWISE SPECIFIED

NOTE
TOLERANCE:
.XXX ± .005"
.XX ± .010
ANGLE ± 1°

THIRD ANGLE PROJECTION
ANSI 14.5M

