

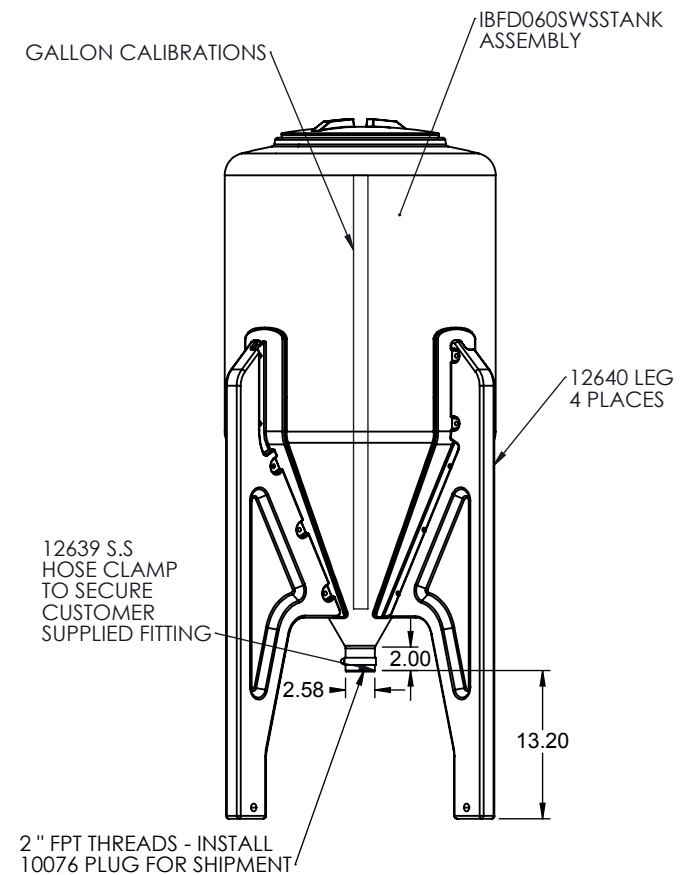

Copyright. All information furnished within this document, electronic file or design correspondence is the property of Den Hartog industries, Inc. and shall not be used, disclosed to others or copied without the expressed written consent of Den Hartog Industries, Inc.

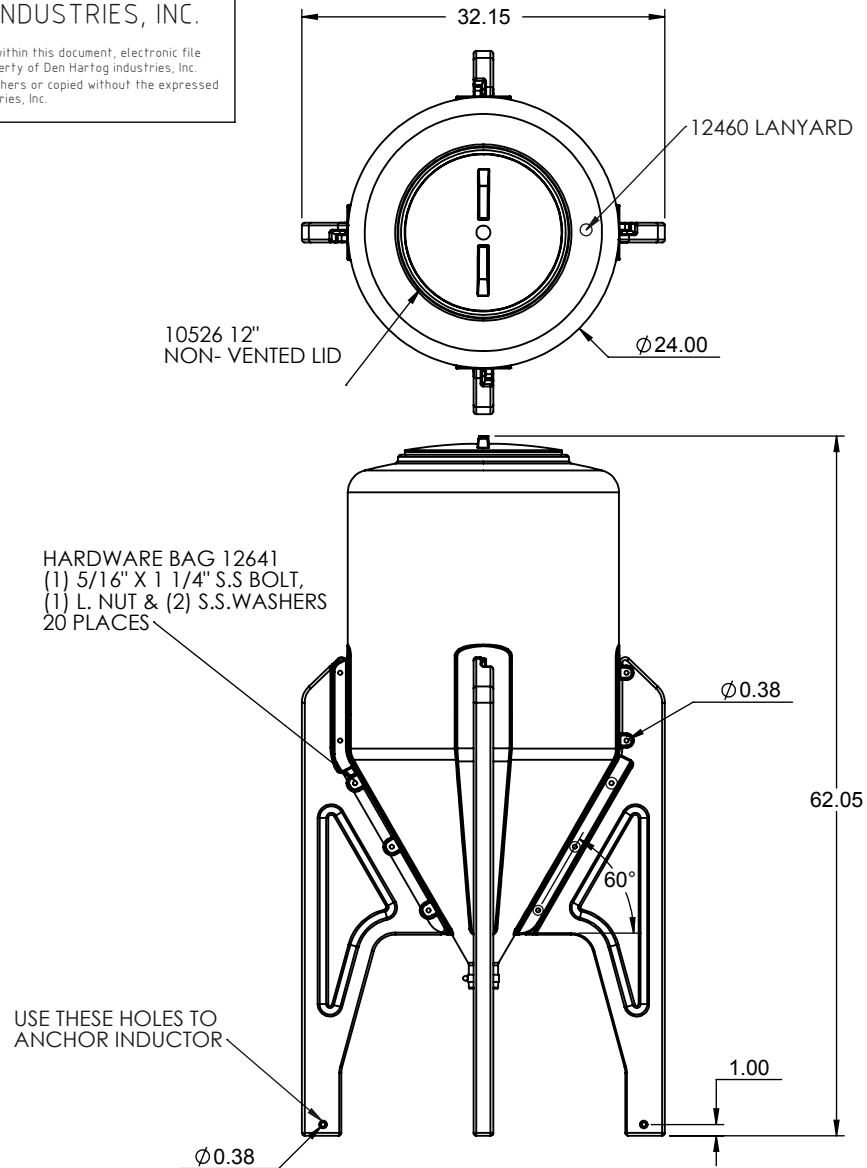

DRAWN / DATE ADH 8/25/08		MATERIAL	
APPROD. / DATE REH 6/10/09		NOTES:	
REV	DESCRIPTION	BY / DATE	CCN
ALL DIMENSIONS ARE IN DECIMAL INCHES TOLERANCES UNLESS OTHERWISE SPECIFIED		THIRD ANGLE PROJECTION ANSI 14.5M	
POLYETHYLENE ±1% @ 68°F		METAL DECIMAL ± .125" FRACTION ± 1/4" ANGLE ± 1°	
SHOT WEIGHT:		SHIPPING WEIGHT:	
FINISH:			



Den Hartog

INDUSTRIES, INC.

Ace Roto-Mold Injection Molding Blow Molding Sowjoy

4010 HOSPERS DRIVE S. BOX 425, HOSPERS, IOWA 51238-0421

DESCRIPTION 60 GALLON BLOW MOLDED INDUCTOR	
SCALE N.S.	PART NO. IBFD60-SET