

PROPRIETARY DATA

PROPERTY OF ACE ROTO-MOLD MFG., INC. INFORMATION FURNISHED HEREIN IS THE PROPERTY OF ACE ROTO-MOLD MFG., INC. AND SHALL NOT BE USED, DISCLOSED TO OTHERS, OR COPIED WITHOUT THE EXPRESSED WRITTEN CONSENT OF ACE ROTO-MOLD MFG., INC. ALL RIGHTS RESERVED.

IN0110-30

A

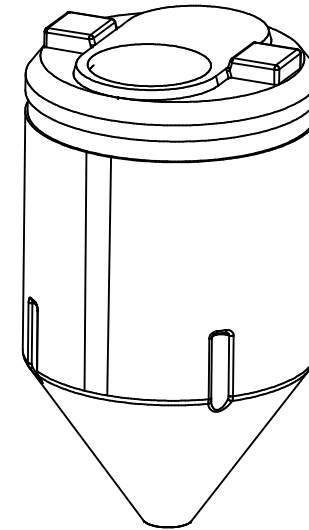
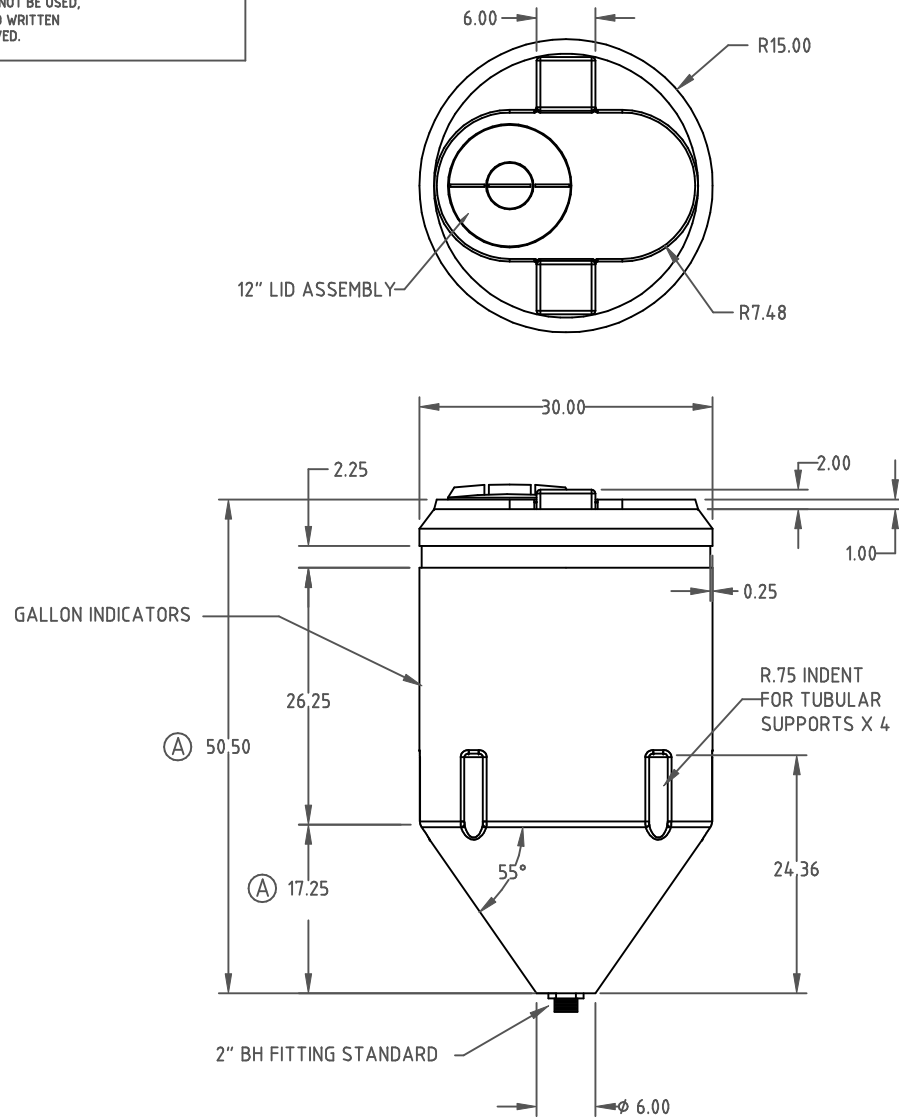

DRAWN / DATE
REH / 6/14/99

MATERIAL

ACE ROTO-MOLD
A DIVISION OF DEN HARTOG INDUSTRIES, INC.
4018 HWY. 60 BLVD., BOX 421, HOSPERS, IOWA 51238

APPRD. / DATE
DHJ / 6/14/99

42 LB. MOBIL 134

CLIENT / DESCRIPTION

110 GAL. INDUCTOR TANK

ALL DIMENSIONS ARE IN DECIMAL INCHES
TOLERANCES UNLESS OTHERWISE SPECIFIED

THIRD ANGLE PROJECTION
ANSI 14.5M

NOTES:
1. NATURAL COLOR
2. NOM. WALL .200

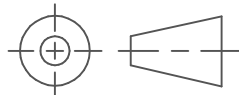

SCALE
N.S.

PART NO.
IN0110-30

± .5% @ 68° F