

Copyright. All information furnished within this document, electronic file or design correspondence is the property of Den Hartog industries, Inc. and shall not be used, disclosed to others or copied without the expressed written consent of Den Hartog Industries, Inc.

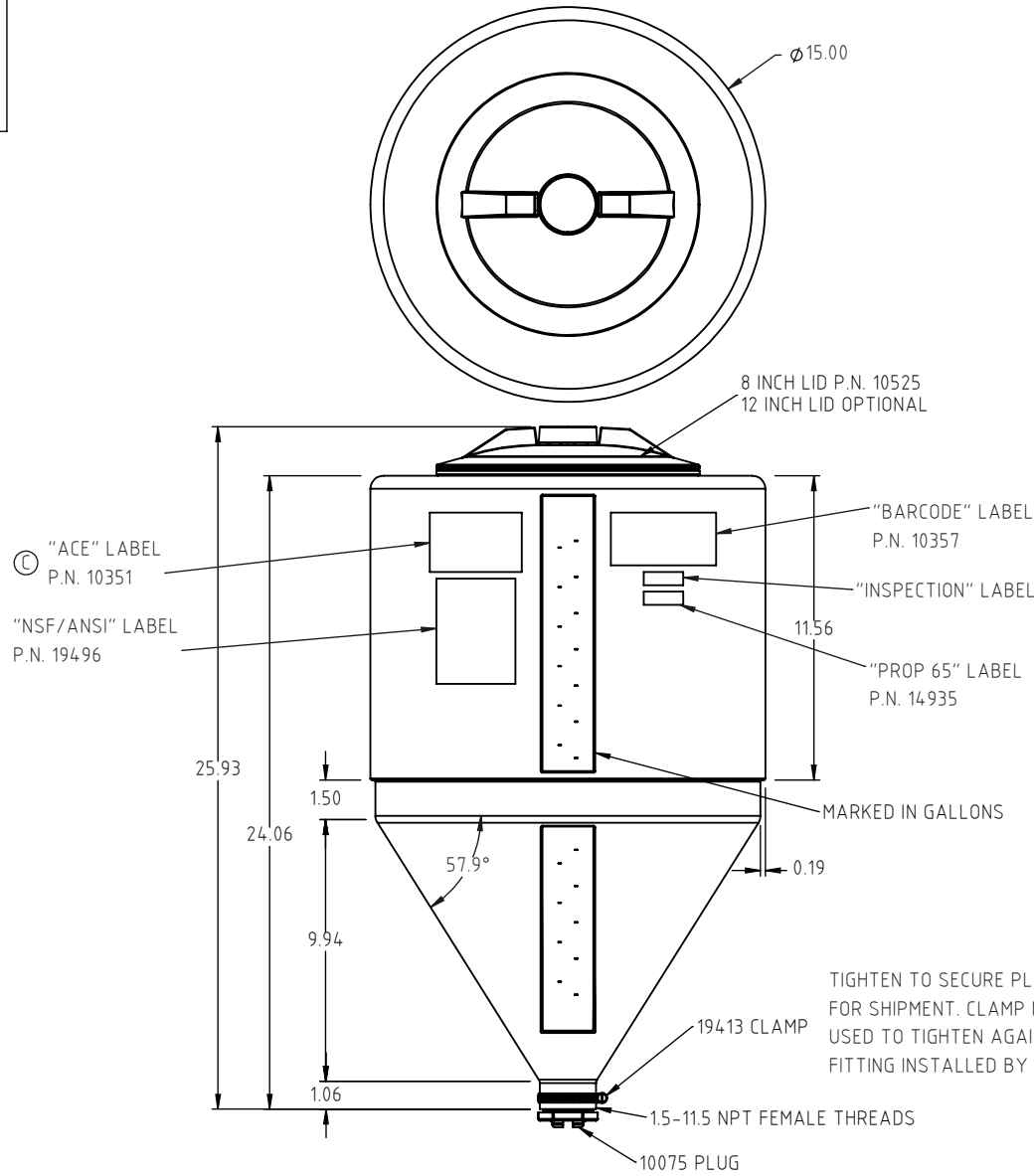

TIGHTEN TO SECURE PLUG FOR SHIPMENT. CLAMP MUST BE USED TO TIGHTEN AGAINST OUTLET FITTING INSTALLED BY CUSTOMER.

C	UPDATED SHEET FORMAT, LAYOUT, & LABELS ADDED TO PRINT.	BES	8/22/24	4542	DRAWN / DATE	MATERIAL :
B	ADD NOTE TO 19413 CLAMP	BES	4/4/2023	4415	DHJ 10/18/2013	LLDPE
A	1.06" WAS 1.50", 9.94" WAS 8.91", 15.0" WAS 1.00", 24.06" WAS 23.13", 11.56" WAS 11.72"	ADH	8/10/18	3611	APPRD. / DATE	
REV.	DESCRIPTION	BY	DATE	CCN	REH 1/27/2014	
ALL DIMENSIONS ARE IN DECIMAL INCHES TOLERANCES UNLESS OTHERWISE SPECIFIED		THIRD ANGLE PROJECTION ANSI 14.5M		SHOT WEIGHT: 7.5 LBS	NOTES: 1.) 0.22" NOM. WALL	
POLYETHYLENE		METAL DECIMAL ± .125" FRACTION ± 1/4" ANGLE ± 1°		SHIPPING WEIGHT: 9.5 LBS		
±1% @ 68°F				FINISH:		

Den Hartog

INDUSTRIES, INC.

Ace Roto-Mold • Injection Molding • Blow Molding • Sowjoy
4010 HOSPERS DRIVE S. BOX 425, HOSPERS, IOWA 51238-0425

DESCRIPTION 10 GALLON FULL DRAIN INDUCTOR TANK		
SCALE N.S.	PART NO. INFD10-15	SHEET 1 OF 1