

Copyright. All information furnished within this document, electronic file or design correspondence is the property of Den Hartog industries, Inc. and shall not be used, disclosed to others or copied without the expressed written consent of Den Hartog Industries, Inc.

ITEM NO.	PART NUMBER	DESCRIPTION	QTY.
1	IN30-55-ST-1	IN, STAND 30/55 LEG PIPE	2
2	IN30-55-ST-2	IN, STAND 30/55 LEG PIPE W/HLE	1
3	IN15-ST-3	IN, STAND 15 GAL RING	1
4	12582	PIPE PLUG, 1/2" BLACK	3
5	IN15-ST-5	IN, STAND 15 GAL ROD	3
6	J.313X3.00	J-BOLT, 5/16" X 3"	1
7	12080	INDUCTOR, BASE STRAP - 15 GAL	3
8	10280	NUT, 5/16" NYLOK ZINC	1

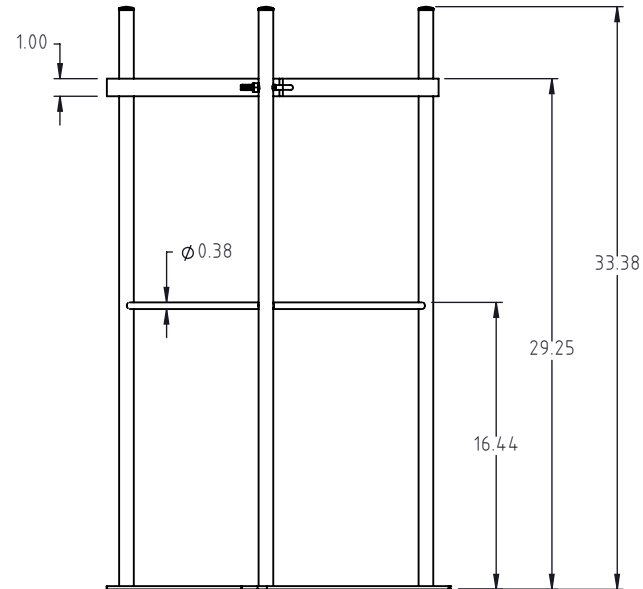

F	UPDATED SHEET FORMAT & LAYOUT. 16.00LBS WAS 15.5LBS.	SRA	8/29/24	4633	DRAWN / DATE	MATERIAL :
E	55 WAS 60	ADH	12/16/2013	2755	ADH 12/11/2007	SEE COMPONENTS
D	IN30-60-ST-1 AND IN30-60-ST-2 WERE INFD15-ST-1 AND INFD15-ST-2, DRAWING TEMPLATE/TABLE UPDATED	ADH	10/13/2011	2300	APPRD. / DATE	⑥
REV.	DESCRIPTION	BY	DATE	CCN	REH 12/14/2007	
ALL DIMENSIONS ARE IN DECIMAL INCHES TOLERANCES UNLESS OTHERWISE SPECIFIED		THIRD ANGLE PROJECTION ANSI 14.5M		SHOT WEIGHT:		NOTES:
POLYETHYLENE		METAL		SHIPPING WEIGHT:		
±1% @ 68°F		DECIMAL ± .125" FRACTION ± 1/4" ANGLE ± 1°		⑥ 16.00 LBS.		
				FINISH:		
				Powder Coat		

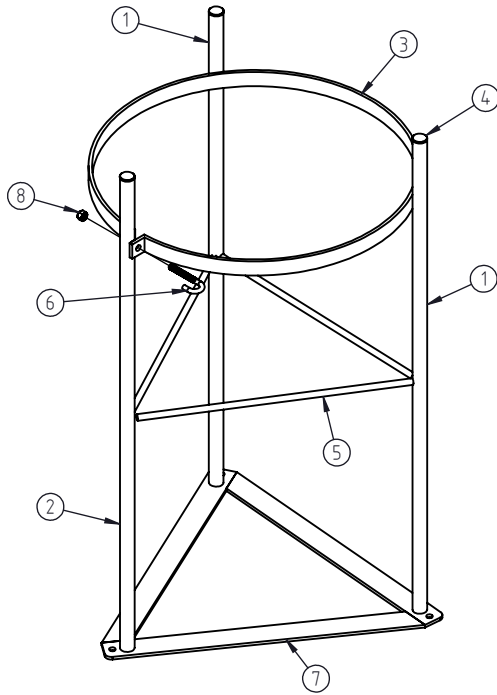
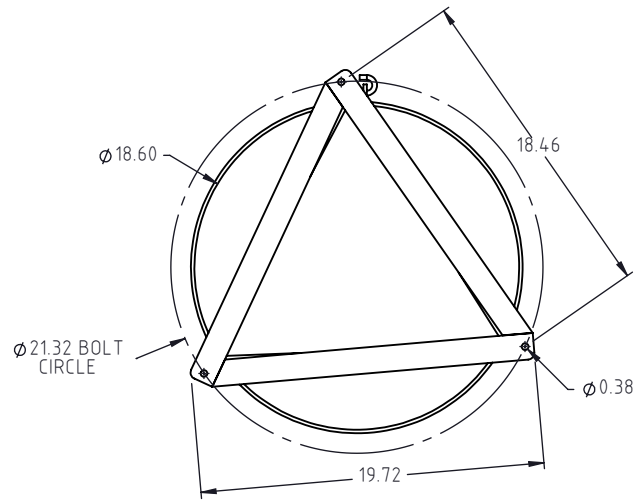

**Den Hartog**  
**INDUSTRIES, INC.**

Ace Roto-Mold • Injection Molding • Blow Molding • Sowjoy  
4010 HOSPERS DRIVE S. BOX 425, HOSPERS, IOWA 51238-0425

DESCRIPTION		IN, STAND 15 GAL FULL DRAIN	
SCALE	N.S.	PART NO.	INFD15-ST
		SHEET	1 OF 1