

Copyright. All information furnished within this document, electronic file or design correspondence is the property of Den Hartog industries, Inc. and shall not be used, disclosed to others or copied without the expressed written consent of Den Hartog Industries, Inc.

ITEM NO.	PART NUMBER	DESCRIPTION	QTY.
1	INFD30-55-ST-1	IN, STAND 30/55 GL LEG PIPE	2
2	INFD30-55-ST-2	IN, STAND 30/55 LEG PIPE W/HLE FULL DRAIN	1
3	IN30-55-ST-3	IN, STAND 30/55 GAL RING	1
4	12582	PIPE PLUG, 1/2" BLACK	3
5	IN30-55-ST-5	IN, STAND 30/55 GAL ROD	3
6	12081	INDUCTOR, BASE STRAP 30/55 GAL	3
7	J.313X3.00	J-BOLT, 5/16" X 3"	1
8	10280	NUT, 5/16" NYLOK ZINC	1

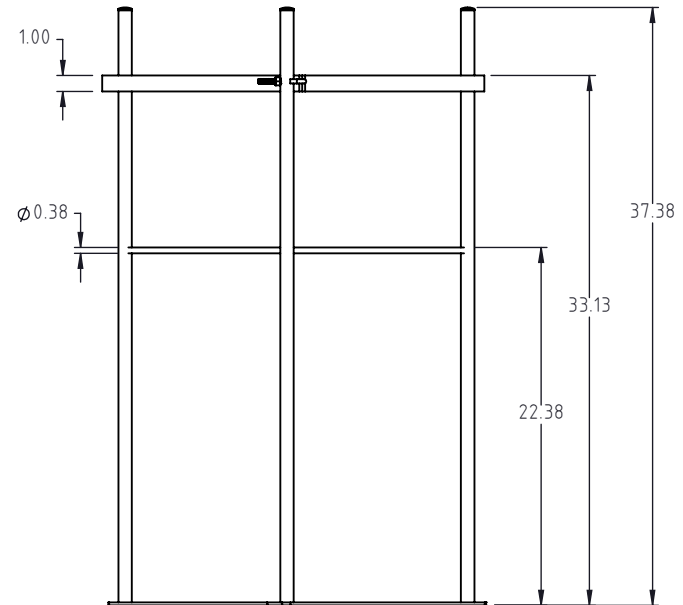
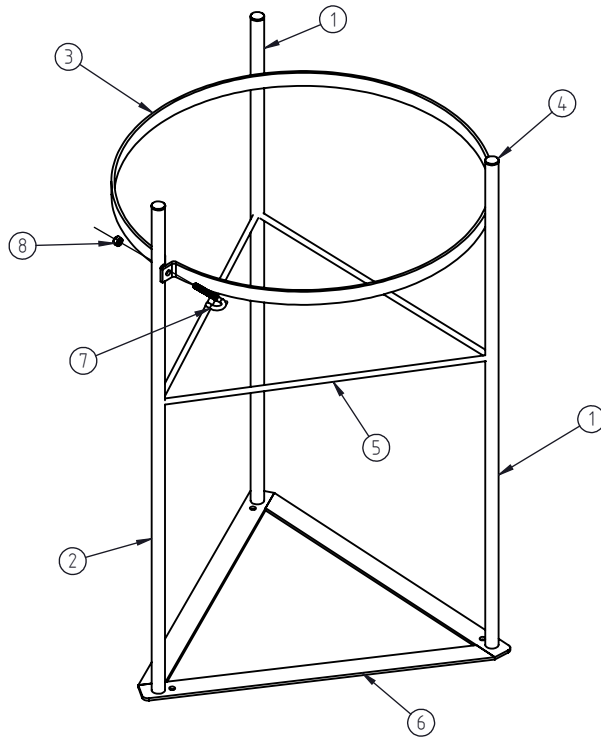
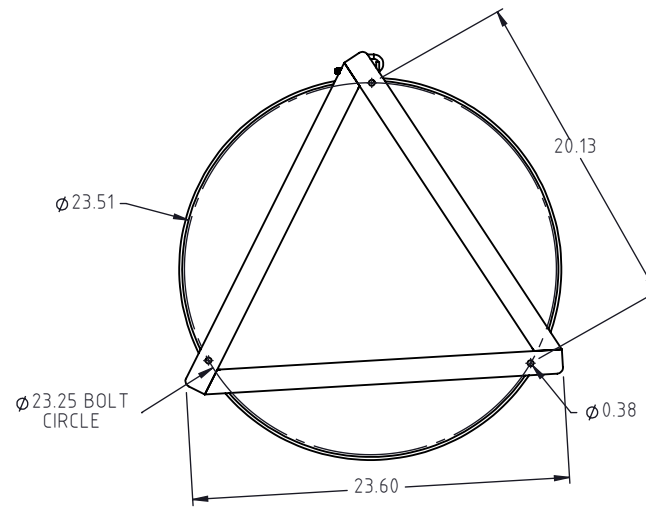

D	UPDATED SHEET FORMAT & LAYOUT. 19.0LBS WAS 18.5LBS.	SRA	8/30/24	4633	DRAWN / DATE	MATERIAL :
C	55 WAS 60, DRAWING TEMPLATE UPDATED	ADH	12/13/2013	2755	ADH 12/12/2007	SEE COMPONENTS
B	DIMENSIONS, BASE STRAPS, AND LEG PLUGS UPDATED	ADH	10/13/2008	1729	APPRD. / DATE	
REV.	DESCRIPTION	BY	DATE	CCN	REH 12/14/2007	
ALL DIMENSIONS ARE IN DECIMAL INCHES TOLERANCES UNLESS OTHERWISE SPECIFIED		THIRD ANGLE PROJECTION ANSI 14.5M		SHOT WEIGHT:		NOTES: DESCRIPTION IN, STAND 30/55 GAL FULL DRAIN SCALE N.S. PART NO. INFD30-55-ST SHEET 1 OF 1
POLYETHYLENE				SHIPPING WEIGHT: 19.0LBS		
METAL DECIMAL ± .125" FRACTION ± 1/4" ANGLE ± 1°				FINISH: Powder Coat		

Den Hartog INDUSTRIES, INC.
 Ace Roto-Mold • Injection Molding • Blow Molding • Sowjoy
 4010 HOSPERS DRIVE S. BOX 425, HOSPERS, IOWA 51238-0425