

PROPRIETARY DATA

PROPERTY OF ACE ROTO-MOLD MFG., INC. INFORMATION FURNISHED HEREIN IS THE PROPERTY OF ACE ROTO-MOLD MFG., INC. AND SHALL NOT BE USED, DISCLOSED TO OTHERS, OR COPIED WITHOUT THE EXPRESSED WRITTEN CONSENT OF ACE ROTO-MOLD MFG., INC. ALL RIGHTS RESERVED.

INFD60-30

A

OUTLET DETAIL

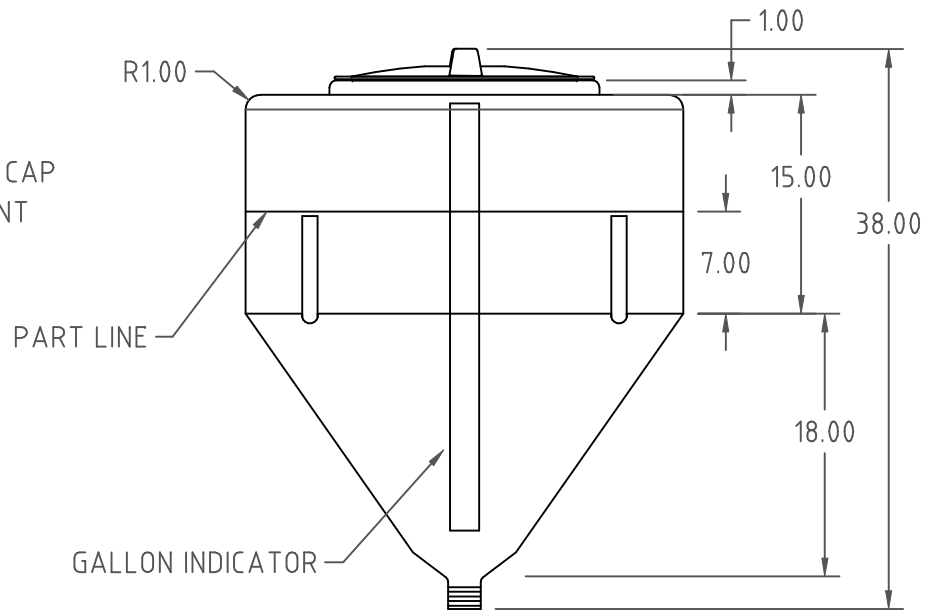
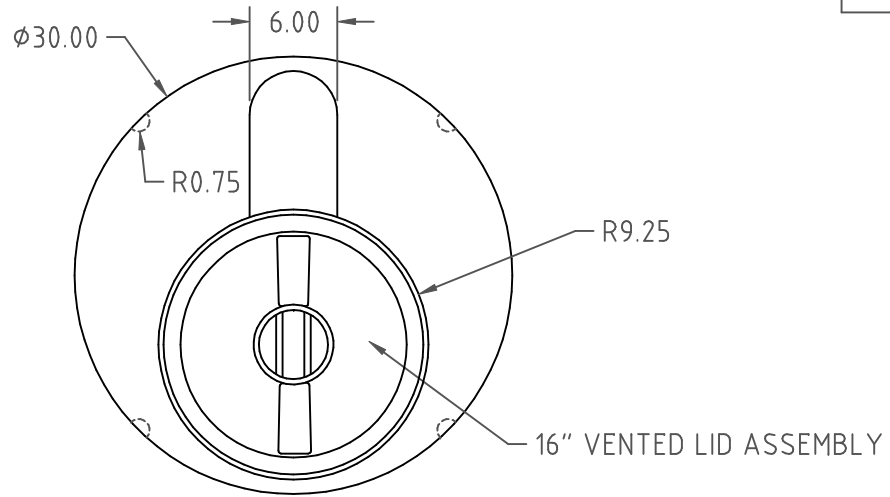
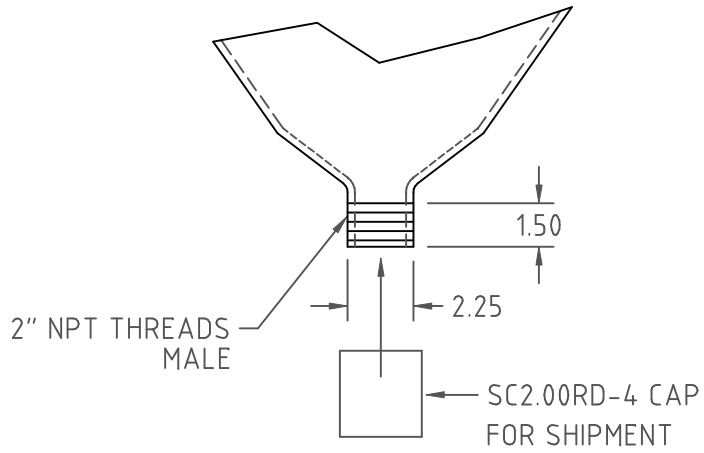

(A)

		DRAWN / DATE		MATERIAL	
		DHJ 9/18/06		26 LB. MOBIL 134	
A	ADDED CAP	CCN1409	8/2/07	REH	APPRD. / DATE
REV	DESCRIPTION	DATE	APPRD	REH	9/26/07
ALL DIMENSIONS ARE IN DECIMAL INCHES TOLERANCES UNLESS OTHERWISE SPECIFIED			THIRD ANGLE PROJECTION ANSI 14.5M		NOTES: 1. NATURAL COLOR 2. NOM. WALL .190
± .5% @ 68° F					

**ACE ROTO-MOLD**  
 A DIVISION OF DEN HARTOG INDUSTRIES, INC.  
 4018 HWY. 60 BLVD., BOX 421, HOSPERS, IOWA 51238

CLIENT / DESCRIPTION	
60 GAL FULL DRAIN INDUCTOR TANK	
SCALE	PART NO.
N.S.	INFD60-30