

Copyright. All information furnished within this document, electronic file or design correspondence is the property of Den Hartog industries, Inc. and shall not be used, disclosed to others or copied without the expressed written consent of Den Hartog Industries, Inc.

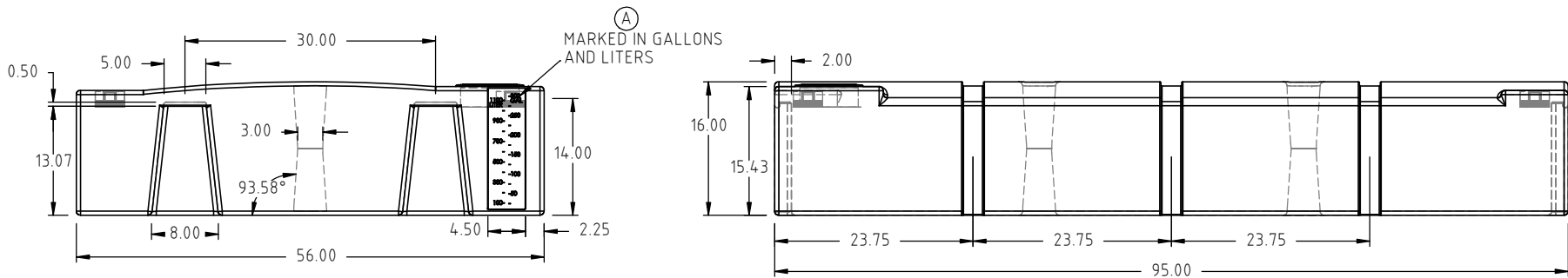

				DRAWN / DATE DHJ 10/21/11	MATERIAL 10420
A	ADD GALLON MARKER INFORMATION TO PRINT.	DHJ 11/6/13	2732	APPRD. / DATE REH 10/23/11	
REV	DESCRIPTION	BY / DATE	CCN		
ALL DIMENSIONS ARE IN DECIMAL INCHES TOLERANCES UNLESS OTHERWISE SPECIFIED		THIRD ANGLE PROJECTION ANSI 14.5M		SHOT WEIGHT: 130.00 LBS	NOTES: 1.) .300 WALL
POLYETHYLENE		METAL DECIMAL ± .125" FRACTION ± 1/4" ANGLE ± 1°		SHIPPING WEIGHT: 132.00 LBS	
±1% @ 68°F				FINISH:	

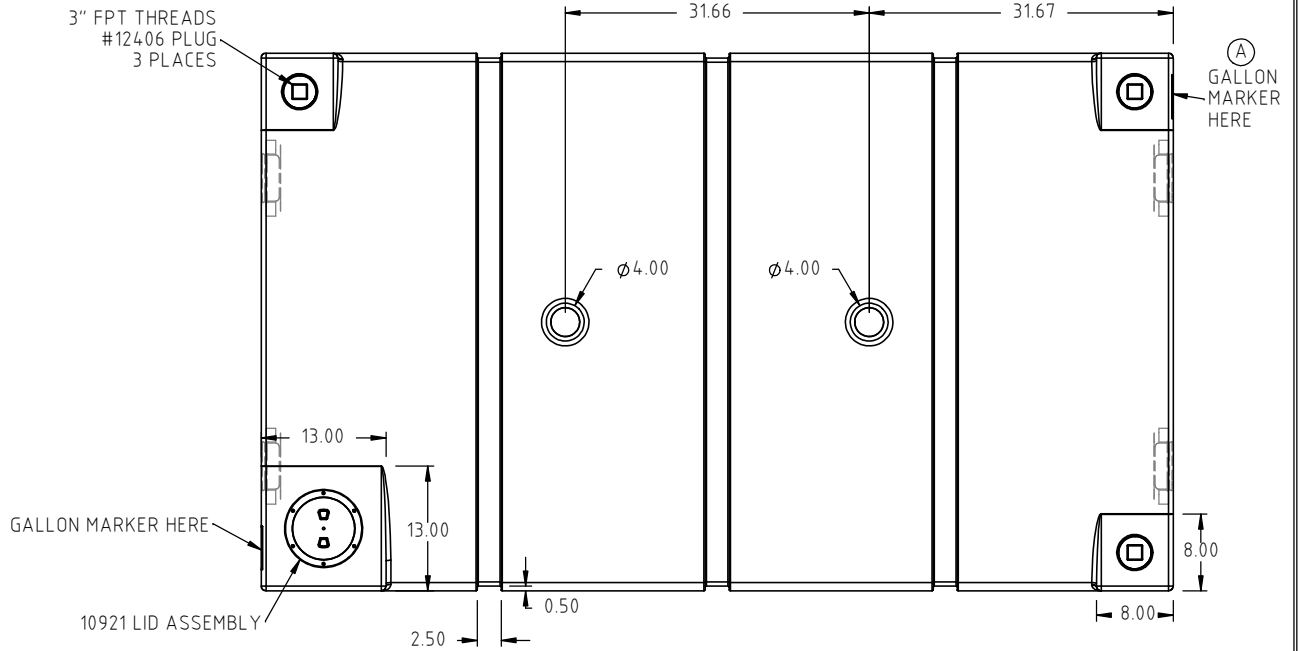

**Den Hartog**  
INDUSTRIES, INC.

Ace Roto-Mold Injection Molding Blow Molding Sowjoy

4010 HOSPERS DRIVE S. BOX 425, HOSPERS, IOWA 51238-0425

DESCRIPTION 300 GALLON LOW PROFILE HOLDING TANK	
SCALE N.S.	PART NO. LP0300-HT