

© DEN HARTOG INDUSTRIES, INC.

Copyright. All information furnished within this document, electronic file or design correspondence is the property of Den Hartog Industries, Inc. and shall not be used, disclosed to others or copied without the expressed written consent of Den Hartog Industries, Inc.

CAUTION LABEL 14676



LPS-1000-1

B

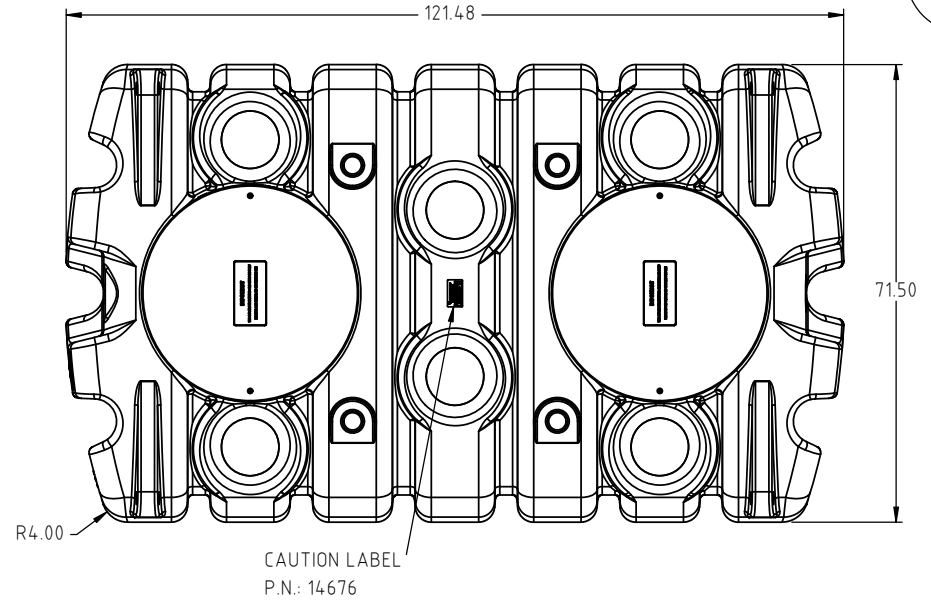

STANDARD TANK SENT WITH TWO 19465 SHIPPING COVERS BUT BURIAL LID(S) AND/OR RISER(S) REQUIRED FOR FINAL INSTALLATION.

BOLT, 3/8" X 1" HEX GR 5 ZINC
P.N.: 10089
X 4

WASHER, 3/8" FLAT ZINC
P.N.: SJ10937
X 4

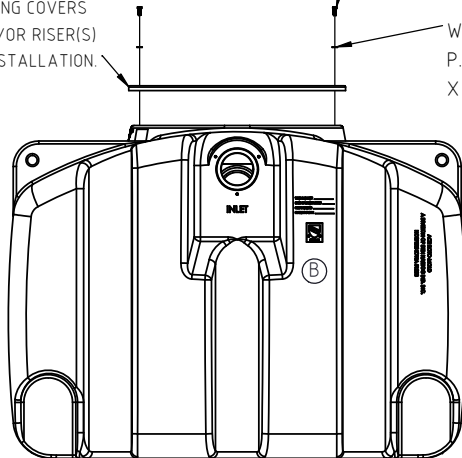

INSTALLED 4" PVC SUPPORTS
P.N.: 14682
X 4

INLET
SIDE

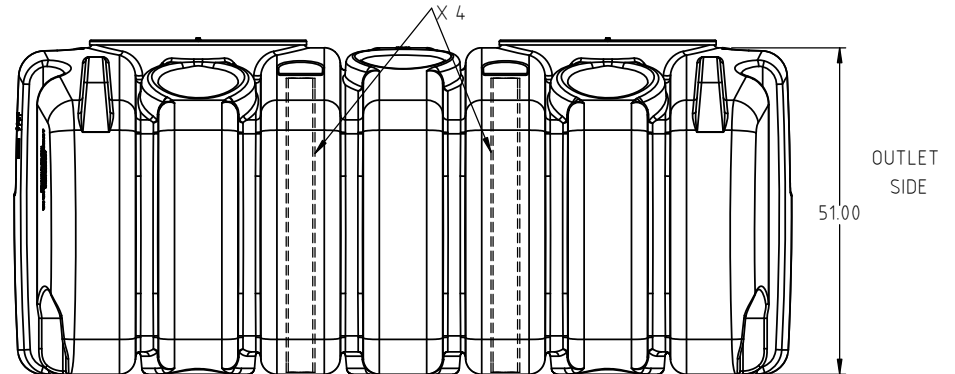

B	MOLDED IN INFORMATION REMOVED FROM PRINT.	ADH	1/10/2022	4229	DRAWN / DATE ADH 12/2/2016	MATERIAL :
A	582.00 LBS. WAS 513.00 LBS.	ADH	11/8/2018	3665	APPRD. / DATE REH 7/19/2017	
REV.	DESCRIPTION	BY	DATE	CCN	SHOT WEIGHT:	NOTES:
	ALL DIMENSIONS ARE IN DECIMAL INCHES TOLERANCES UNLESS OTHERWISE SPECIFIED				SHIPPING WEIGHT: 582.00 LBS.	
	POLYETHYLENE				FINISH:	
	METAL DECIMAL ± .125" FRACTION ± 1/4" ANGLE ± 1°					

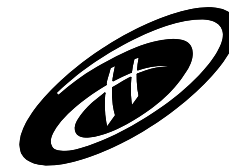
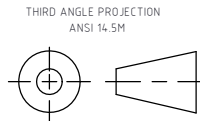

Den Hartog INDUSTRIES, INC.

Ace Roto-Mold • Injection Molding • Blow Molding • Sowjoy
4010 HOSPERS DRIVE S. BOX 425, HOSPERS, IOWA 51238-0425

DESCRIPTION	1000 GALLON LOW PROFILE SINGLE COMPARTMENT SEPTIC TANK ASSEMBLY AS SHIPPED	
SCALE	N.S.	SHEET 1 OF 2
PART NO.	LPS-1000-1	

Copyright. All information furnished within this document, electronic file or design correspondence is the property of Den Hartog Industries, Inc. and shall not be used, disclosed to others or copied without the expressed written consent of Den Hartog Industries, Inc.

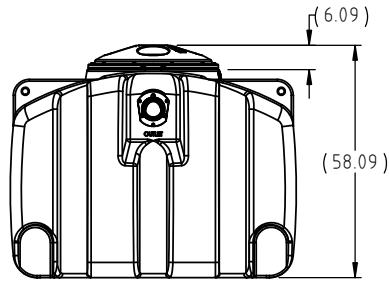

OPTIONAL
BURIAL LID ASSEMBLY
P.N.= ACT-16053BK
SHOWN

LID/COVER OPTIONS.
(TWO COMPLETE COVERS
REQUIRED FOR INSTALLATION).

- 1.) BURIAL LID ASSEMBLY
P.N.=ACT-16053BK
- 2.) 16" GROUND ACCESS RISER
P.N.=ACT-16054BK
- 3.) 28" GROUND ACCESS RISER
P.N.=ACT-16052BK
- 4.) 7" EXTENSION (REQUIRES RISER)
P.N.=AST19365
- 5.) 16" EXTENSION (REQUIRES RISER)
P.N.=AST19212

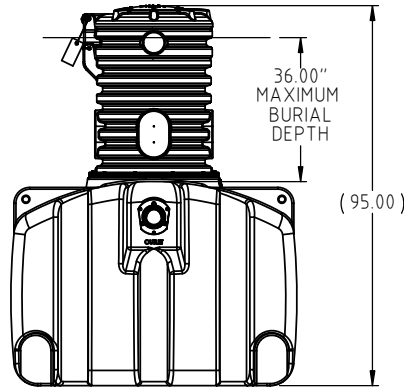

OPTIONAL
28" GROUND ACCESS RISER (ACT-16052BK)
AND 7" EXTENSION (AST19365)
SHOWN

KEY	PART NUMBER	DESCRIPTION	QTY.
1	LPS-1000	1000 GAL LOW PROFILE SEPTIC TANK	1
2	AST19153	CLAMP, STABILIZER	2
3	10087	BOLT, 1/4" X 3/4" HEX GR5 ZINC	6
4	10626	WASHER, 1/4" FLAT ZINC	6
5	14682	PIPE, 4" SEPTIC/CISTERN SUPPORT PVC	4
6	19465	ACT, CISTERN SHIPPING COVER	2
7	SJ10937	WASHER, 3/8" FLAT ZINC	4
8	10089	BOLT, 3/8" X 1" HEX GR 5 ZINC	4
9	14676	LABEL, CAUTION SEPTIC	1

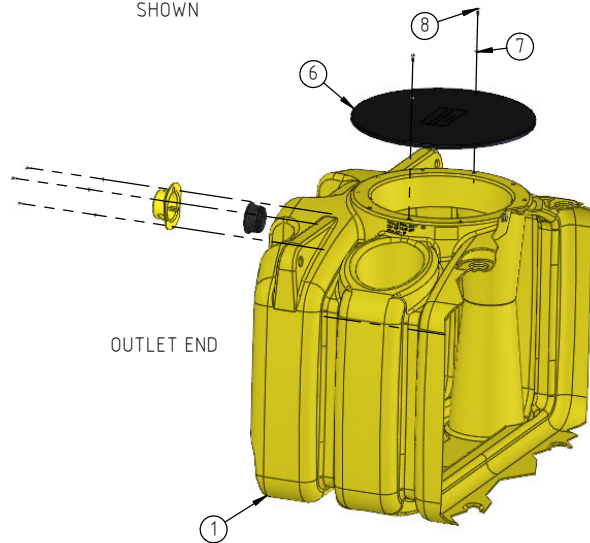

OUTLET END

TANK SHOWN SPLIT
FOR REFERENCE ONLY

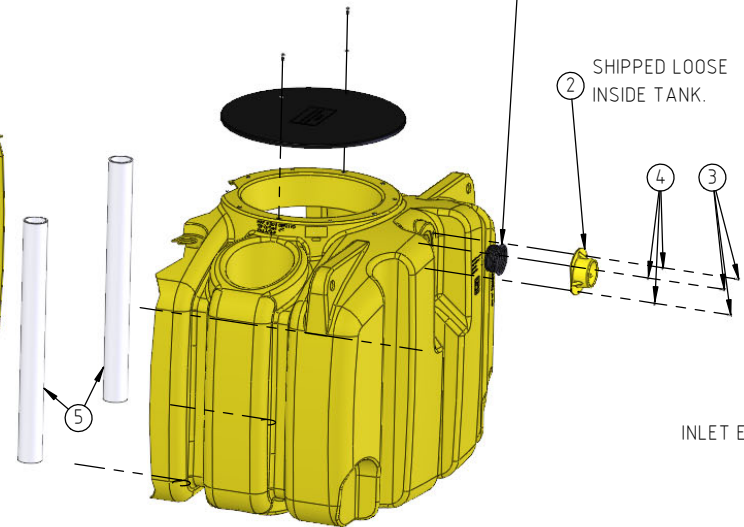
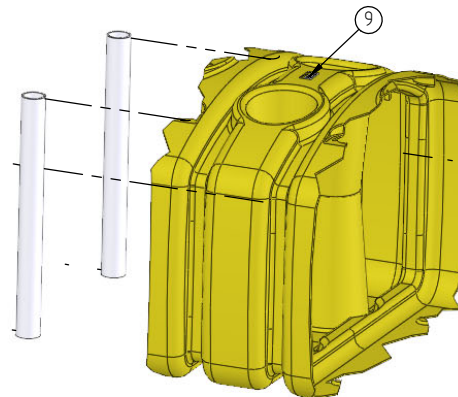

INLET END

AST10084 GASKET
FURNISHED AS PART OF
PLUMBING KIT IF ORDERED.

SHIPPED LOOSE
INSIDE TANK.

SHIPPED IN
19090 BAG
(SCREWED TO
SLOSH GUARD)

REV.	DESCRIPTION	BY	DATE	CCN	DRAWN / DATE	MATERIAL :
					ADH 12/2/2016	
ALL DIMENSIONS ARE IN DECIMAL INCHES TOLERANCES UNLESS OTHERWISE SPECIFIED	THIRD ANGLE PROJECTION ANSI 14.5M	SHOT WEIGHT:	SHIPPING WEIGHT:	FINISH:	NOTES:	APPRD. / DATE
POLYETHYLENE	METAL DECIMAL ± .125" FRACTION ± 1/4" ANGLE ± 1°					
±1% @ 68°F						

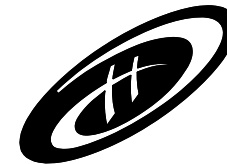

**Den Hartog
INDUSTRIES, INC.**

Ace Roto-Mold • Injection Molding • Blow Molding • Sowjoy
4010 HOSPERS DRIVE S. BOX 425, HOSPERS, IOWA 51238-0425

DESCRIPTION 1000 GALLON LOW PROFILE SINGLE COMPARTMENT SEPTIC TANK ASSEMBLY AS SHIPPED		SHEET. 2 OF 2
SCALE N.S.	PART NO. LPS-1000-1	